

Operation Manual

TempoGate[®] Smart Assistant for R-Series V



V
THE NEW GENERATION

Table of Contents

1. Introduction	3
1.1 Purpose and use of this manual	3
1.2 Used symbols and warnings	3
2. Safety instructions	3
2.1 Intended use	3
2.2 Foreseeable misuse	3
2.3 Installation, commissioning and operation	4
2.4 Safety instructions for use in explosion-hazardous areas	4
2.5 Warranty	4
2.6 Return	4
2.7 Removal from service/dismantling	4
3. Order code	5
4. Product description	6
4.1 Functionality and system design	6
4.2 Installation of the TempoGate® smart assistant	7
4.3 Electrical connection	11
5. Configuration for network integration	13
6. Operation	20
6.1 The User Interface of the TempoGate® smart assistant	20
6.2 Menu item TempoGate	23
6.3 Menu item Status	28
6.4 Menu item Sensor Info	32
6.5 Menu item Parameters	32
6.6 Menu item interface	34
7. Output data via OPC UA	35
8. Recovery	36
9. Technical data	37

1. Introduction

1.1 Purpose and use of this manual

Before starting the operation of Temposonics position sensors, read this documentation thoroughly and follow the safety information. Keep this manual for future reference!

The content of this technical documentation is intended to provide information on mounting, installation and commissioning by qualified automation personnel¹ or instructed service technicians who are familiar with the project planning and dealing with Temposonics products.

1.2 Used symbols and warnings

Warnings are intended for your personal safety and for avoidance of damage to the described product or connected devices. In this documentation, safety information and warnings to avoid danger that might affect the life and health of operating or service personnel or cause material damage are highlighted by the pictogram, defined below.

Symbol	Meaning
NOTICE	This symbol is used to point to situations that may lead to material damage, but not to personal injury.

2. Safety instructions

2.1 Intended use

This product may be used only for the applications defined under item 1 and only in conjunction with the third-party devices and components recommended or approved by Temposonics. As a prerequisite of proper and safe operation the product requires correct transport, storage, mounting and commissioning and must be operated with utmost care.

- The sensor systems of all Temposonics® series are intended exclusively for measurement tasks encountered in industrial, commercial and laboratory applications. The sensors are considered as system accessories and must be connected to suitable evaluation electronics, e.g. a PLC, IPC, indicator or other electronic control unit.

- 1/ The term "qualified technical personnel" characterizes persons who
- are familiar with the safety concepts of automation technology applicable to the particular project
 - are competent in the field of electromagnetic compatibility (EMC) or
 - have received adequate training for commissioning and service operations
 - and are familiar with the operation of the device and know the information required for correct operation provided in the product documentation

- TempoGate® smart assistant is an accessory for Temposonics® R-Series V sensors for reading out and adjusting of sensor parameters as well as monitoring status values.

2.2 Foreseeable misuse

Foreseeable misuse	Consequence
Wrong sensor connection	The sensor and TempoGate® smart assistant will not work properly or can be damaged
Power supply is out of the defined range	The TempoGate® smart assistant can be damaged
Cables are damaged	Short circuit – the sensor and TempoGate® smart assistant can be destroyed/sensor does not respond
Wrong connection of ground / shield	Signal output is disturbed The electronics can be damaged

Do not alter the TempoGate® smart assistant afterwards.
→ The unit might be damaged.

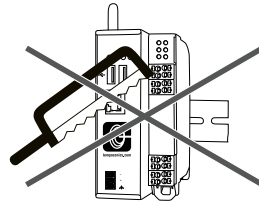

Do not step on the TempoGate® smart assistant.
→ The unit might be damaged.

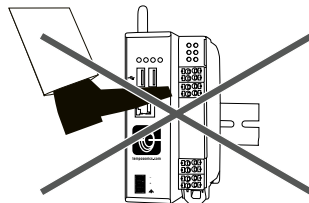

2.3 Installation, commissioning and operation

The position sensors and TempoGate® smart assistant must be used only in technically safe conditions. To maintain this condition and to ensure safe operation, installation, connection and service, work may be performed only by qualified technical personnel.

If danger of injury to persons or of damage to operating equipment is caused by sensor failure or malfunction, additional safety measures such as plausibility checks, limit switches, EMERGENCY STOP systems, protective devices etc. are required. In the event of trouble, shut down the sensor and protect it against accidental operation.

Safety instructions for commissioning

To maintain the sensor's and TempoGate® smart assistant's operability, it is mandatory to follow the instructions given below.

1. Protect the sensor and TempoGate® smart assistant against mechanical damage during installation and operation.
2. Do not open or dismantle the sensor and TempoGate® smart assistant.
3. Connect the sensor and TempoGate® smart assistant very carefully and pay attention to the polarity of connections and power supply.
4. Use only approved power supplies.
5. Ensure the sensor and TempoGate® smart assistant are operating within the defined limits for supply voltage, environmental conditions, etc.
6. Check the function of the sensor and TempoGate® smart assistant regularly and provide documentation of the checks.
7. Before applying power, ensure that nobody's safety is jeopardized by starting machines.

2.4 Safety instructions for use in explosion-hazardous areas

The TempoGate® smart assistant is not suitable for operation in explosion-hazardous areas.

2.5 Warranty

Temposonics grants a warranty period for their position sensors and supplied accessories relating to material defects and faults that occur despite correct use in accordance with the intended application.² The Temposonics obligation is limited to repair or replacement of any defective part of the unit. No warranty can be provided for defects that are due to improper use or above average stress of the product, as well as for wear parts. Under no circumstances will Temposonics accept liability in the event of offense against the warranty rules, no matter if these have been assured or expected, even in case of fault or negligence of the company.

Temposonics explicitly excludes any further warranties. Neither the company's representatives, agents, dealers nor employees are authorized to increase or change the scope of warranty.

2.6 Return

For diagnostic purposes, the TempoGate® smart assistant can be returned to Temposonics or a repair facility explicitly authorized by Temposonics. Any shipment cost is the responsibility of the sender ². For a corresponding form, see operation manuals of the R-Series V sensors (available at: www.temposonics.com).

2.7 Removal from service/dismantling

The product contains electronic components and must be disposed of in accordance with the local regulations.

^{2/} See also applicable Temposonics sales and supply conditions, e.g. under www.temposonics.com

3. Order code

1	2	3	4	5	6	7
T	G		0	D		
a		b		d		

a	Type
T G	TempoGate® smart assistant kit

b	Power supply per channel at the connection module
C	Common power supply for all channels via connection module 1
I	Individual power supply for each channel

c	Options
0	No options

d	Number of digital channels for connection of R-Series V
D X X	D02...D24 (02...24 channels for R-Series V EtherCAT®, EtherNet/IP™, POWERLINK, PROFINET or SSI) only even number of digital channels possible
Connection module for connecting the R-Series V Analog follows later.	

DELIVERY



TempoGate® smart assistant kit

- TempoGate® smart assistant gateway
- Depending on the selected configuration: one to four connection modules for 2...24 digital R-Series V sensors
- Power supply for gateway (3 pin connector)

4. Product description

4.1 Functionality and system design

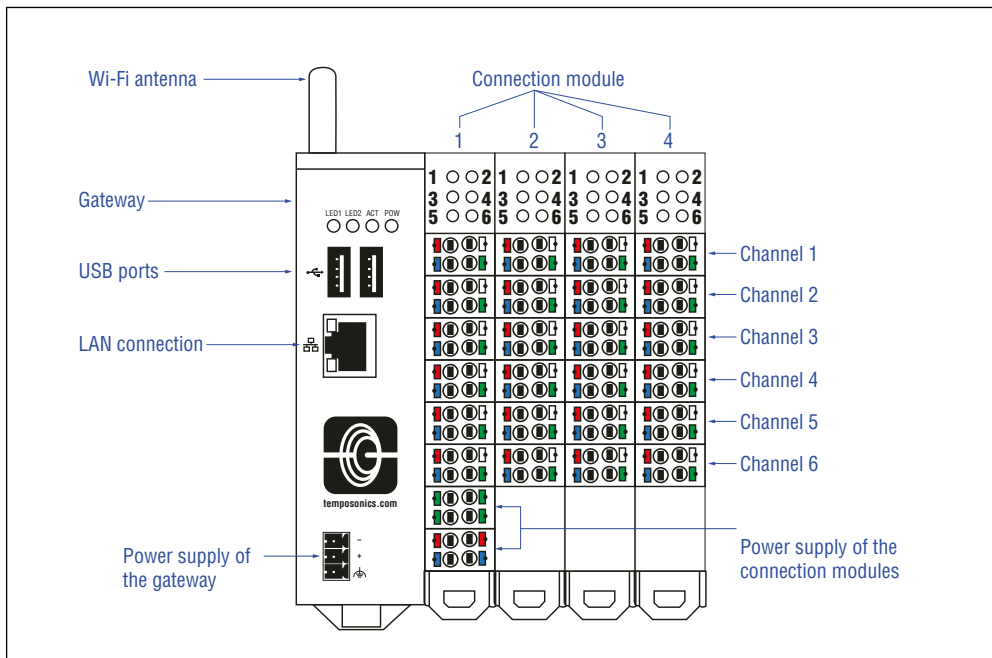

Fig. 1: TempoGate® smart assistant with gateway and four connection modules

Product designation

- TempoGate® smart assistant

Application

The TempoGate® smart assistant is used to read out additional information and to set parameters of an R-Series V sensor. The additional information is read during operation independently of the transmission of process data to the controller.

Setup of the TempoGate® smart assistant

The TempoGate® smart assistant consists of a gateway and, depending on the configuration, one or more connection modules (Fig. 1).

- The gateway contains the Wi-Fi module and the LAN connection for the network connection.
- A connection module has up to six channels, to each of which an R-Series V sensor with digital output (EtherCAT®, EtherNet/IP™, POWERLINK, PROFINET and SSI) can be connected.
- A gateway can be connected with up to four connection modules.

4.2 Installation of the TempoGate® smart assistant

TempoGate® gateway

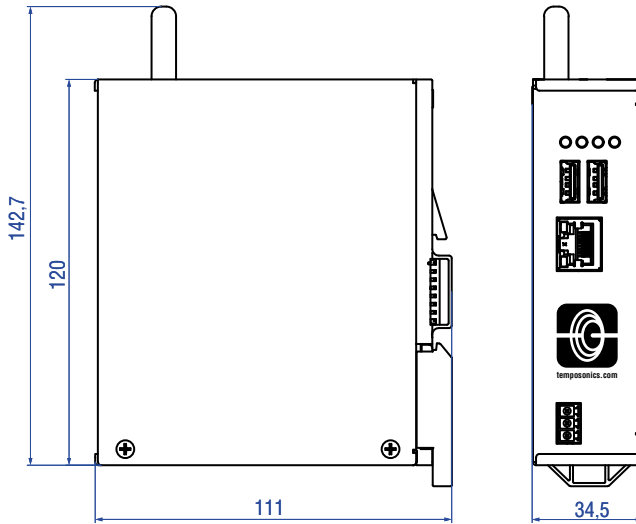

TempoGate® connection module

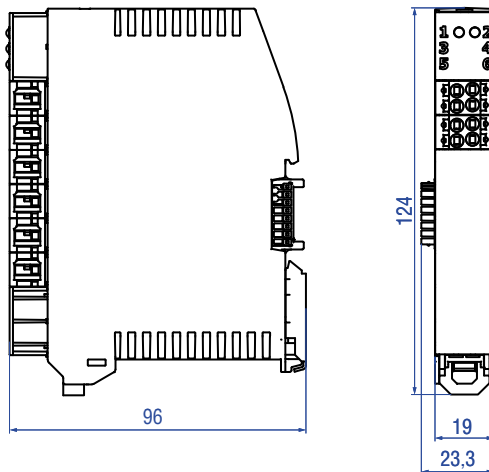

Controlling design dimensions are in millimeters and measurements in () are in inches

Fig. 2: TempoGate® gateway and connection module

Installing the TempoGate® smart assistant in a control cabinet

The components of the TempoGate® smart assistant are designed for installation in a control cabinet. The gateway and the connection modules are equipped with clamps for mounting the components on a 35 mm standard rail.

1. Plug the gateway onto the 35 mm standard rail and snap it onto the DIN rail (Fig. 3).
2. The connection module is mounted onto the 35 mm standard rail via the DIN rail connector.
 - a. For transport, the DIN rail connector is mounted on each connection module. Remove the DIN rail connector from the connection module.
 - b. Plug the DIN rail connector of a connection module onto the 35 mm standard rail and snap it onto the rail (Fig. 4).
 - c. Place the connection module onto the DIN rail connector from above by hooking the upper housing groove onto the upper edge of the DIN rail connector.
 - d. Push the connection module in the direction of the mounting surface and snap it into the DIN rail connector (Fig. 6). Mount further modules in the same way.
3. Move the connection modules with the DIN rail connectors to the gateway (Fig. 7). Make sure that the DIN rail connectors are completely inserted into the mating connector. Secure the connection modules against accidental slipping out with a suitable top-hat rail clamp.

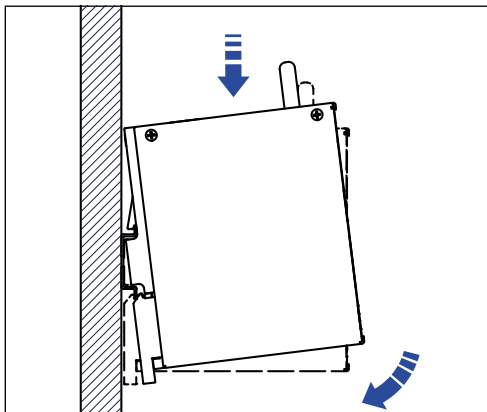

Fig. 3: Installation of the gateway of the standard rail

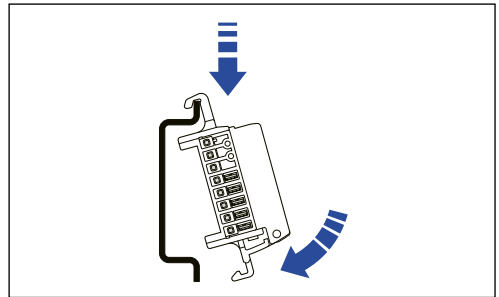

Fig. 4: Placing and snapping the DIN rail connector on the standard rail

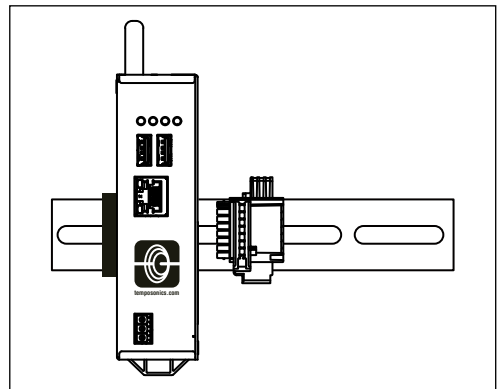

Fig. 5: DIN rail connector next to TempoGate® gateway on the standard rail

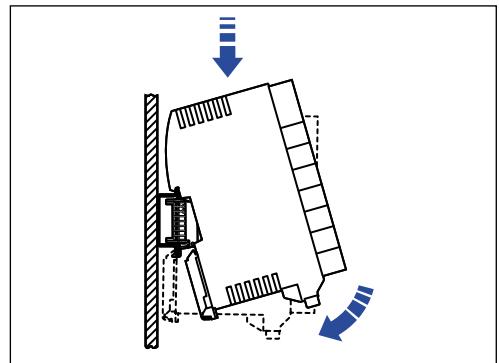

Fig. 6: Mounting the connection module on the DIN rail connector

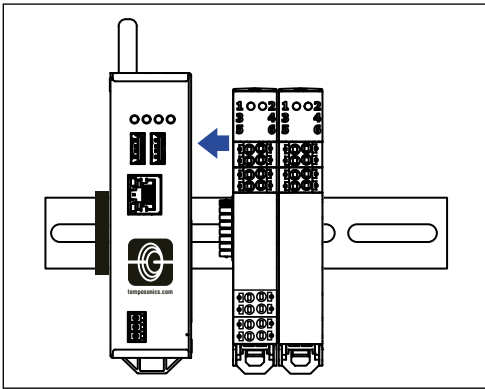

Fig. 7: Moving and connecting the connection modules to the gateway

Removing the TempoGate® smart assistant

Releasing the gateway from the 35 mm standard rail:

1. Before removing the gateway, disconnect the power supply and the data lines from the gateway.
2. Move the TempoGate® gateway to the left (Fig. 8).
3. Insert a screwdriver through the opening of the bracket of the gateway.
4. Push the bracket down to release the lock of the bracket.
5. Remove the gateway from the 35 mm standard rail.

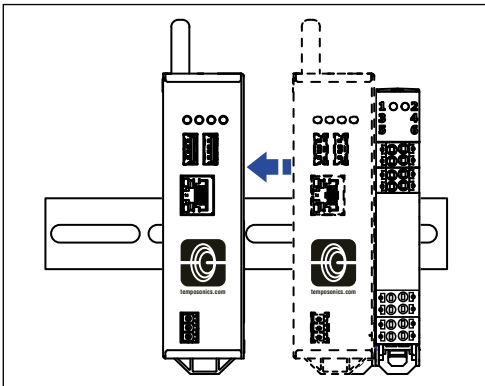

Fig. 8: Moving the TempoGate® gateway to the left to remove it from the 35 mm standard rail

NOTICE

Disconnect the TempoGate® gateway from the connection modules before removing it from the standard 35 mm rail by moving it to the left. Otherwise the connection to the DIN rail connector may be damaged.

Release the connection module from the 35 mm standard rail:

1. Remove all cables from the connection module. Use a screwdriver to press in the push button in each case and pull out the conductor.
2. Insert a screwdriver through the bracket of the connection module (Fig. 9).
3. Hook the tip of the screwdriver into the base latch.
4. Push down on the bracket to release the latch.
5. Remove the connection module from the DIN rail connector.
6. Release the DIN rail connector from the 35 mm standard rail.

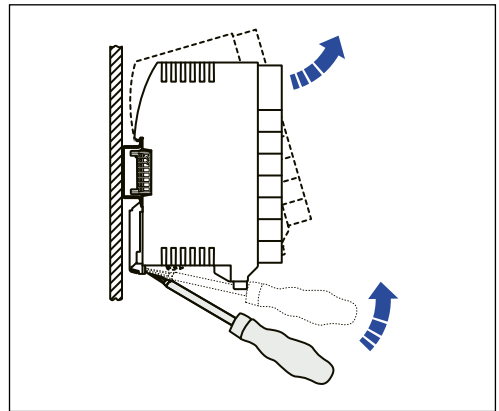

Fig. 9: Release the connection module from the DIN rail connector

TempoGate® smart assistant

Operation Manual

Release the connectors of the connection module:

1. Insert a screwdriver through the opening of the bracket of the connection module (Fig. 10).
2. Hook the tip of the screwdriver into the base latch.
3. Pull the screwdriver forward to release the locking mechanism of the connectors. The connectors are lifted and the contact is released. But the connectors do not fall out. The housing cover remains in its position.

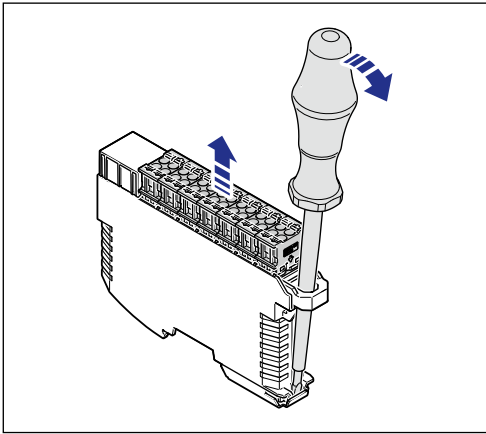

Fig. 10: Removing all connectors

4.3 Electrical connection

4.3.1 Connection of R-Series V Sensors to a connection module

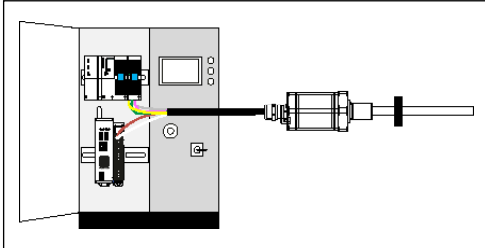

Fig. 11: Schematic diagram for simultaneous connection of the R-Series V to a TempoGate® smart assistant and a controller using the R-Series V with SSI output as an example.

The R-Series V sensors are connected to the TempoGate® smart assistant via their power supply. The sensors are supplied with voltage via the Smart Assistant. Connect the power supply wires of an R-Series V sensor to one channel of a connection module. Only one R-Series V sensor can be connected per channel.

NOTICE

Each connection of a sensor to the connection module must be made with a shielded cable. The maximum cable length is 30 m.

R-Series V EtherCAT®, EtherNet/IP™, POWERLINK, PROFINET: Connect the two wires of the power supply to one channel of the connection module according to (Fig. 12).

R-Series V SSI:

Separate the two wires for the power supply from the four wires for the connection to the control unit. Connect the two wires for the power supply as described in Fig. 12. Connect the other four wires (data (-), data (+), clock (+) and clock (-)) to your controller as usual.

Channel	Cable	Push-In-Connection
	+ 24 VDC for sensor	Push-Button Red
	DC Ground for sensor	Push-Button Blue
	*	Push-Button White
	Shield	Push-Button Green

When connecting the cable shield, the twisted screen should be extended with a suitable stranded wire. The contacts are internally connected to the top-hat rail.

Fig. 12: Assignment at the connection module when connecting an R-Series V sensor

*In the configuration **[T G-I]**... (Individual power supply for each channel) connect the input voltage for this channel to push button white. For the configuration **[T G-C]**... (Common power supply for each channel) this push button is not assigned. For further information regarding the power supply per channel at the connection module, see section 4.3.3 Power supply for gateway and connection modules.

4.3.2 Connect and disconnect wires to the connection modules via push-in connection

The conductors must be solid or prepared with ferrules. Insert the stripped wire into the round opening of the terminal block. For stranded conductors without ferrule push in the push button next to the opening with a screwdriver to open the spring. Insert the the stripped conductor into the round opening of the terminal and release the push button.

To release the terminals, press the push-button next to the round the round opening with a screwdriver and pull out the conductor.

Connection data	
Stripping length w/o ferrule	8...9.5 mm
Ferrule	8...10 mm
Conductor cross section, solid	0.2...1.5 mm ²
Conductor cross section, stranded	0.2...2.5 mm ²
Conductor cross section, stranded, with ferrule, w/o plastic sleeve	0.25...1.5 mm ²
Conductor cross section, stranded, with ferrule, with plastic sleeve	0.25...1.5 mm ²

Fig. 13: Connection data

4.3.3 Power supply for gateway and connection modules

Power supply gateway

Use the 3-pin connector for the power supply. The pin assignment of the connector is shown in Fig. 14. Insert the plug into the socket on the gateway.







DC 24 V	Pin	Signal	Description
	-	DC Ground	Ground
	+	+24 VDC	+24 VDC
		FE	Functional earth

Fig. 14: Pin assignment connector (gateway)

Power supply connection modules

Connect the power supply for the first connection module via the push-in connection as described above. Further connection modules are supplied with voltage via the first module when they are correctly inserted into one another on the 35 mm standard rail.

Channel	Cable	Push-In-Connection
	+24 VDC for connection module*	Push-In Red
	DC Ground for connection module and sensors	Push-In Blue
	Shielding	Push-In Green

* In case of a common power supply per channel also for the channels resp. the connected sensors

Fig. 15: Pin assignment for power supply on the connection module

Common and individual power supply for each channel

For the power supply of the channels resp. the sensors connected to the connection modules, choose in the order code of the kit whether this is done via the power supply of the connection module (common power supply for each channel) or separately for each sensor (individual power supply for each channel) (Table 1).

Common power supply for each channel	Individual power supply for each channel
 <p>+24 VDC</p>	 <p>+12...30 VDC (±20 %)</p> <p>+12...30 VDC (±20 %)</p> <p>+12...30 VDC (±20 %)</p> <p>+12...30 VDC (±20 %)</p> <p>+24 VDC</p>
<p>Only power supply required at the first connection module to supply all channels</p>	<p>Supply power to the connection module and each channel separately. This enables, for example:</p> <ul style="list-style-type: none"> • Measuring and monitoring the power supply of individual sensors • Resetting of individual sensors by disconnecting the individual power supply • Different power supplies per channel in the range +12...30 VDC (±20 %)

Table 1: Difference between common and individual power supply for each channel. This example is showing a connection module with four channels

5. Configuration for network integration

The TempoGate® smart assistant can be integrated into a network via a LAN or Wi-Fi connection. By default, the device has the following IP addresses:

- For the LAN connection: 192.168.50.50
- For the Wi-Fi connection: 192.168.1.1

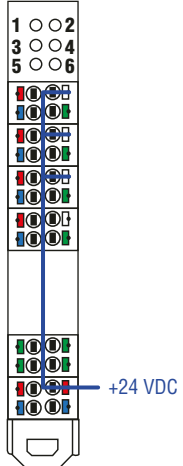
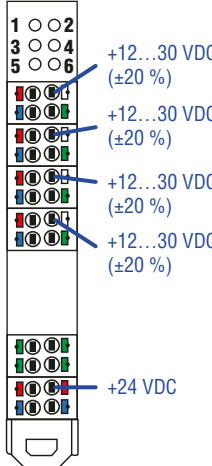
Integrating the TempoGate® smart assistant via LAN:

- Connect the TempoGate® smart assistant to your computer using a network cable (Fig. 16).
- In your computer's network settings, set the IP address 192.168.50.xx with xx ≠ 50, e.g. 192.168.50.42, and the subnet mask 255.255.255.0
- Open the browser on your computer and call the following address: <https://192.168.50.50:8080>

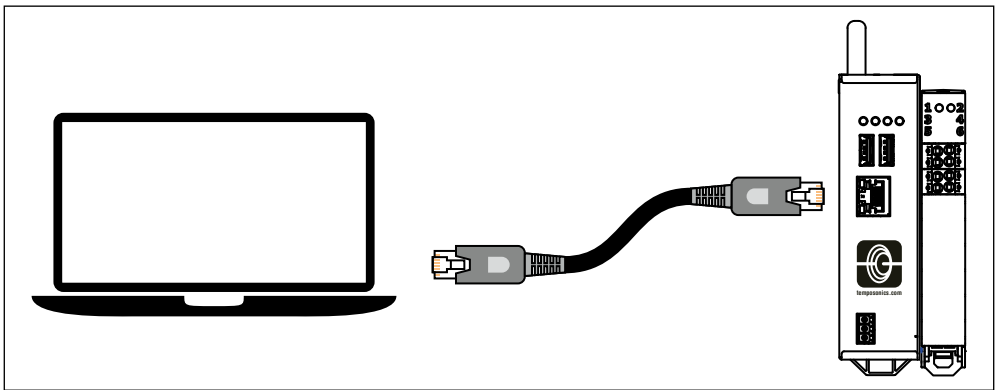

Fig. 16: LAN connection between computer and TempoGate® smart assistant

Integrating the TempoGate® smart assistant via Wi-Fi:

- Activate Wi-Fi on your computer or mobile device and choose the network „TempoGate_XXXX“ (XXXX indicates the MAC address of your TempoGate® smart assistant. The MAC address is printed on the label, which is attached to one the side of the gateway).
- The access to Wi-Fi is password protected. The default password is *userconfigadmin*
- Open the browser on your computer or mobile device and call the following address: <https://192.168.1.1:8080>

NOTICE

The TempoGate® gateway contains a certificate. This certificate is not stored in the browser. Due to that, the browser signals an insecure connection and requests the confirmation to continue. When this confirmation has been given once, any future connections will be established without further requests.

Use the above IP address to access the control panel of the TempoGate® smart assistant. Log in to the control panel with the user name *user_config_admin* and the password *userconfigadmin* (Fig. 17).

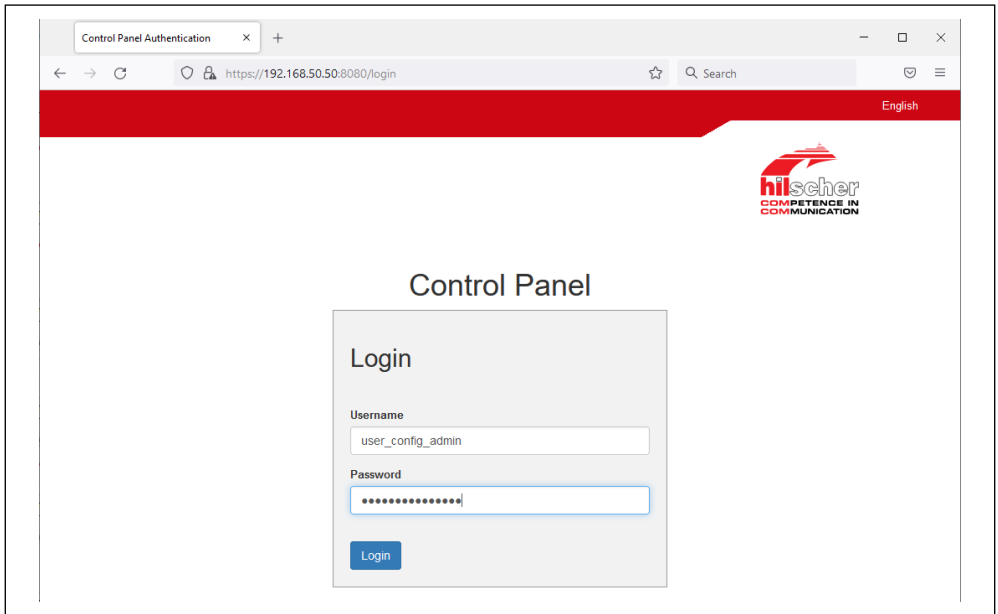

Fig. 17: Login on the Control Panel

The control panel opens. In the upper area of the control panel, you find the main menu with the following entries:

- System
- Package Manager
- Network
- Services
- User Management
- Security
- Help
- Sessions

Some selected entries of the control panel are described below:

LAN and Wi-Fi settings

To adjust the LAN and Wi-Fi settings, open the "Network" drop-down menu in the menu bar and select the "LAN" or "Wi-Fi" entry (Fig. 18). On the "Wi-Fi" page, you can adjust the following settings via the "Mode" entry (Fig. 19):

- Disabled: Deactivating Wi-Fi on the TempoGate® smart assistant.
- Access Point: Using the TempoGate® smart assistant as Wi-Fi access point. This enables other Wi-Fi-capable devices to establish a connection with the TempoGate® smart assistant and its peripheral devices.
- Client: Using TempoGate® smart assistant as a client, which is integrated into a network. This allows the integration of the TempoGate® smart assistant into an already existing Wi-Fi network.

You can change the password for the Wi-Fi access via the "Pre-shared key" entry.

NOTICE

If you make changes to the Wi-Fi settings, it may be necessary to re-establish the connection according to the changed configuration.

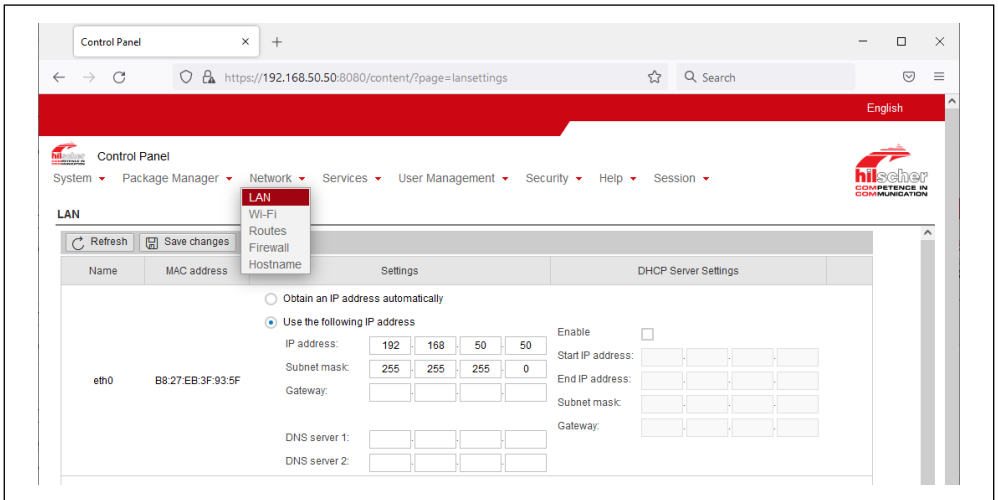

Fig. 18: Opening the network settings on the control panel

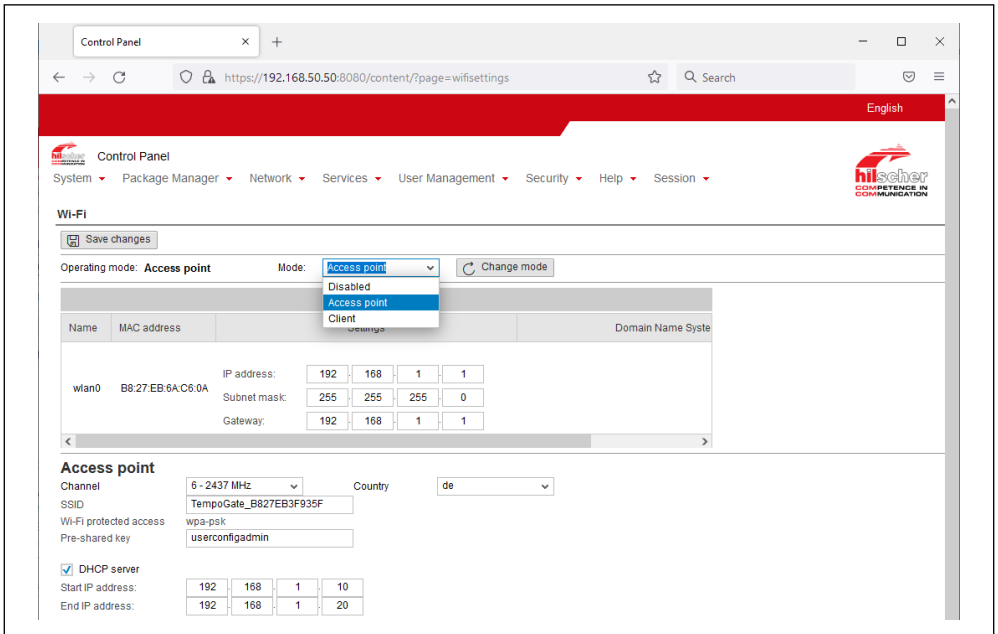

Fig. 19: Wi-Fi settings on the control panel

Setting the system time

The Info Center of the control panel displays current system information about the TempoGate® gateway (Fig. 20). The system time is also displayed on this page. The system time is used as a time stamp when transferring data via OPC UA. To adjust the system time, open the "System" drop-down menu in the menu bar and select the "Time" entry. You can set the system time and the time zone to which this time refers. You can set the system time in two ways:

- Manual: Manually by entering date and time
 - Click the option "Manual".
 - Enter the time in the input field "Time" in the format hh:mm:ss.
 - Set the date using the calendar input field "Date".
 - Click the button "Save changes", to submit these changes.
 - Reboot the device by clicking the entry "Reboot" in the drop down menu "System". The reboot secures that all software components of the TempoGate® smart assistant take the changed time.
- NTP synchronized: Automatically using a time server
You can synchronize the time using a time server that uses the Network Time Protocol (NTP). Under "NTP synchronized" there is a list where you can enter such time servers. The list of NTP servers will be worked off from top to bottom until a server gives a valid answer and synchronization occurs
 - Click the option "NTP Synchronized".
 - Click "Add NTP server", to open the window "Add NTP server".
 - In the input field "NTP server" enter the address of a sever which uses the NTP to synchronize the time.
 - Click "Add", to add this server.
 - Click the button "Save changes", to submit these changes.
 - Reboot the device by clicking the entry "Reboot" in the drop down menu "System". The reboot secures that all software components of the TempoGate® smart assistant take the changed time.

With the selection list "Timezone" you can adjust the time zone to your local time in which the TempoGate® smart assistant is so that the set time can be interpreted correctly (e.g. summer time conversion). For this purpose, the selection list "Timezone" offers many setting options. The default value is "Universal". For Central European Time set "CET".

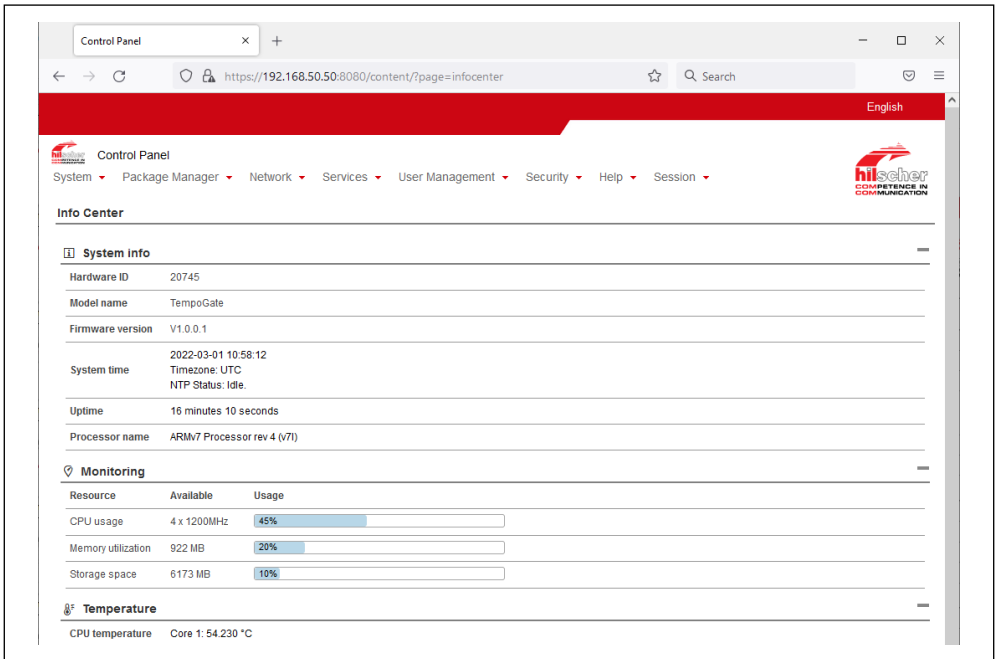

Fig. 20: Info Center of the control panel

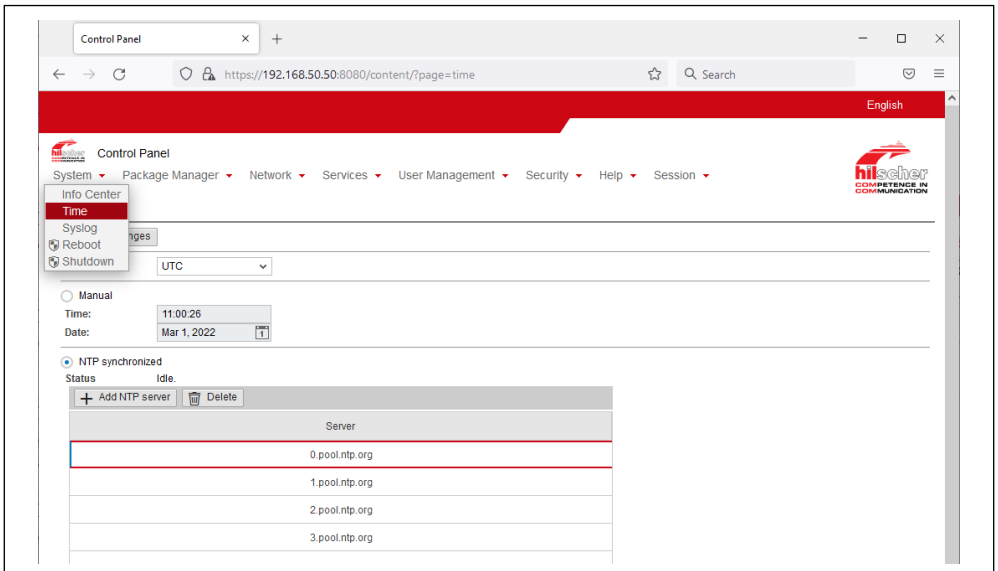

Fig. 21: Time settings

Changing the password

To change the password for accessing the control panel, open the "Session" entry in the menu bar and click on the "User Profile" entry in the drop-down menu (Fig. 22). Click the "Edit User Account" button to open the corresponding window. To change the password, proceed as follows:

- Check the Checkbox "change user password".
- Specify your password in the input field "New password".
- Confirm your input by specifying your password again in the input field "Confirm password".
- Click the button "Save changes", to submit these changes.

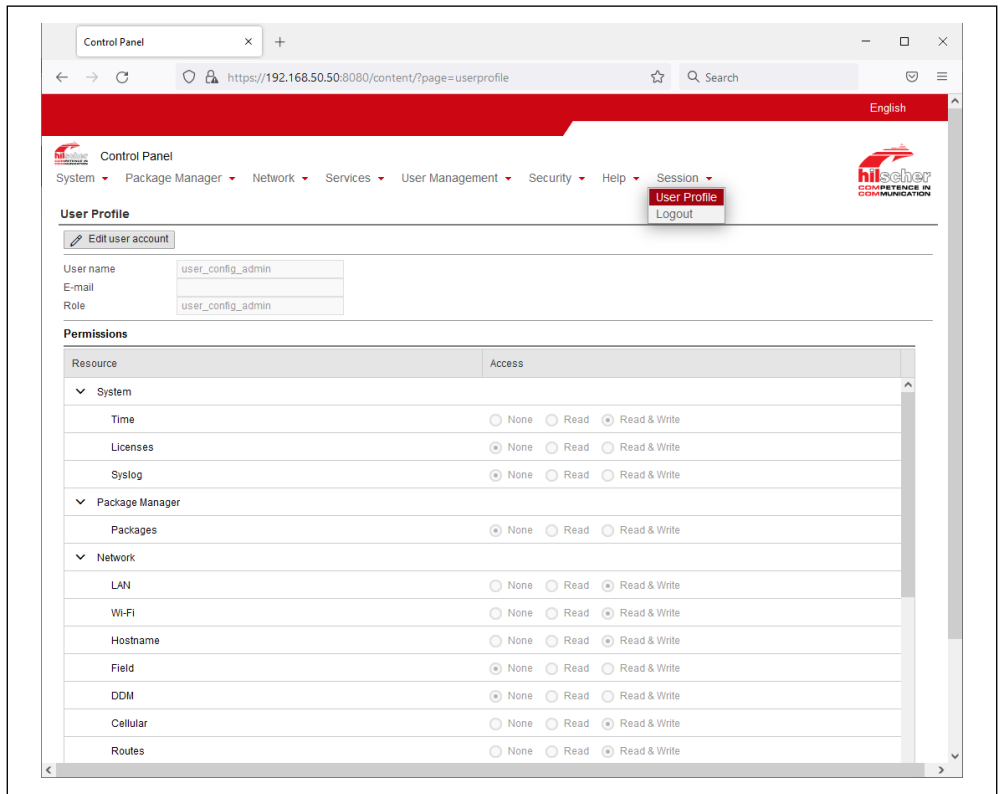

Fig. 22: The window "User Profile"

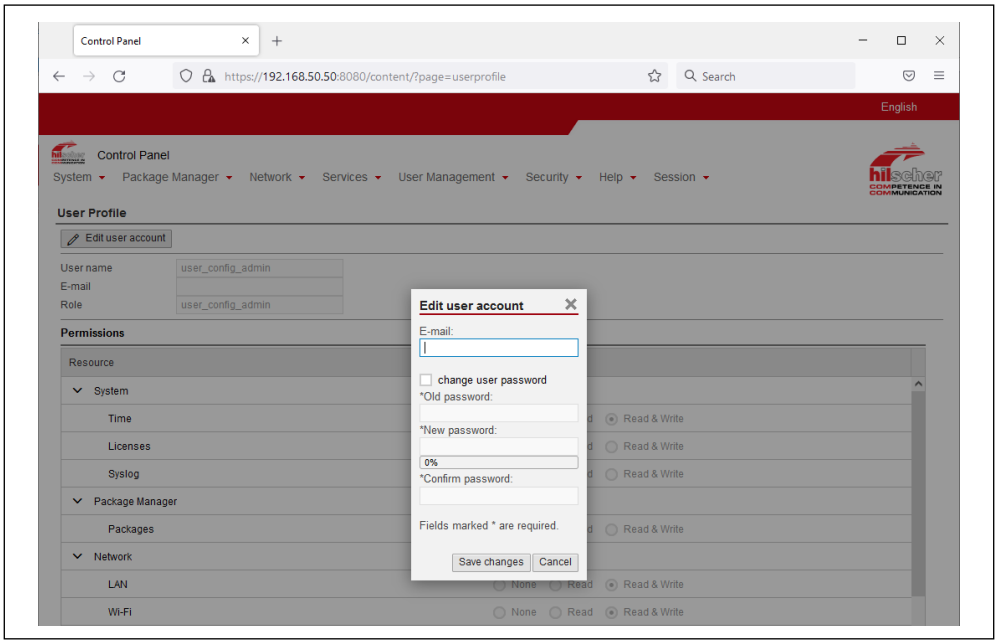

Fig. 23: Password change

Logout from control panel

To log out from the control panel, open the "Session" entry in the menu bar and click on the "Logout" entry in the drop-down menu (Fig. 24).

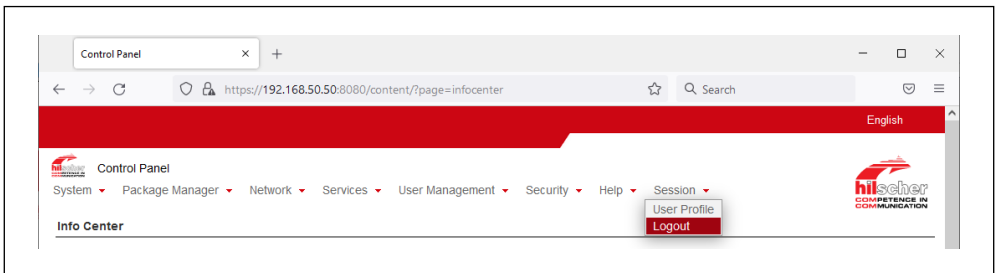

Fig. 24: Logout from control panel

6. Operation

6.1 The User Interface of the TempoGate® smart assistant

Access the user interface of the TempoGate® smart assistant by entering the IP address for the LAN or Wi-Fi connection in your browser. The default IP addresses are:

- For LAN connection: 192.168.50.50
- For Wi-Fi connection: 192.168.1.1

To allow only authorized access to user interface of the TempoGate® smart assistant, the access is password protected. After entering the IP address, you will be prompted to log in with a user name and password (Fig. 25). The default settings are:

- Username: *tempogate*
- Password: *tempogate*

The main menu of the user interface then opens (Fig. 26).

It is recommended to use a current version of the browsers Mozilla Firefox, Google Chrome, Microsoft Edge or Apple Safari.

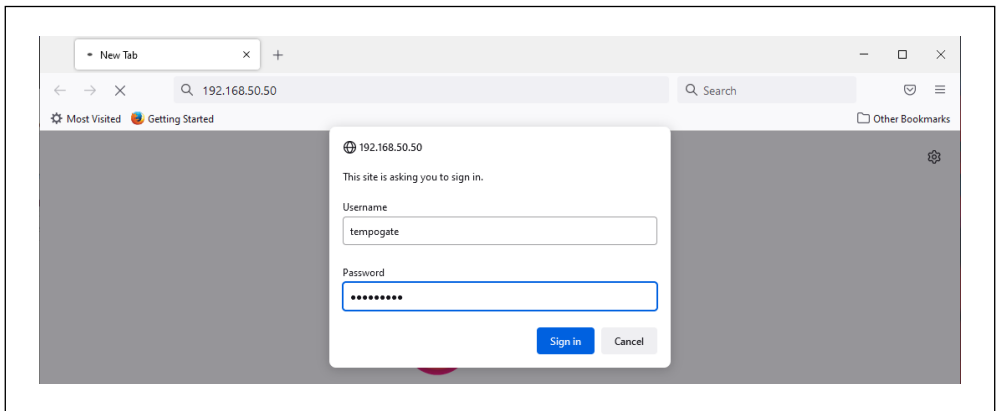

Fig. 25: Login to the user interface of the TempoGate® smart assistant

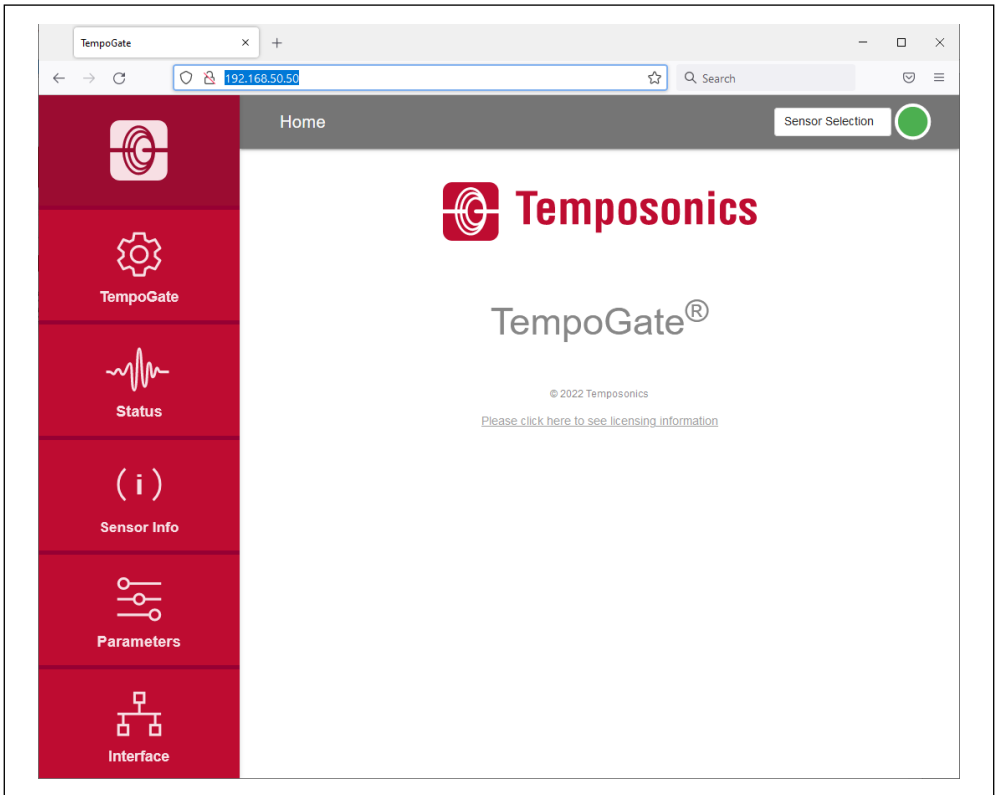

Fig. 26: Main menu of the user interface

Up to 24 R-Series V sensors with digital output (SSI, EtherNet/IP™, EtherCAT®, POWERLINK and PROFINET) can be connected to a TempoGate® smart assistant. One sensor at a time is displayed and can be configured via the user interface. In the "Sensor Selection" drop-down menu the sensors detected at startup are displayed (Fig. 27).

To display the values and settings of a sensor, select a sensor from this menu. In this example, one connection module (Module: 1) is connected to the gateway. Five sensors are connected to this connection module, as Port: 1 (Channel: 1), Port: 2 (Channel: 2), Port: 3 (Channel: 3), Port: 5 (Channel: 5) or Port: 6 (Channel: 6) can be selected. The sensor whose values are displayed and settings can be adjusted is shown in this field.

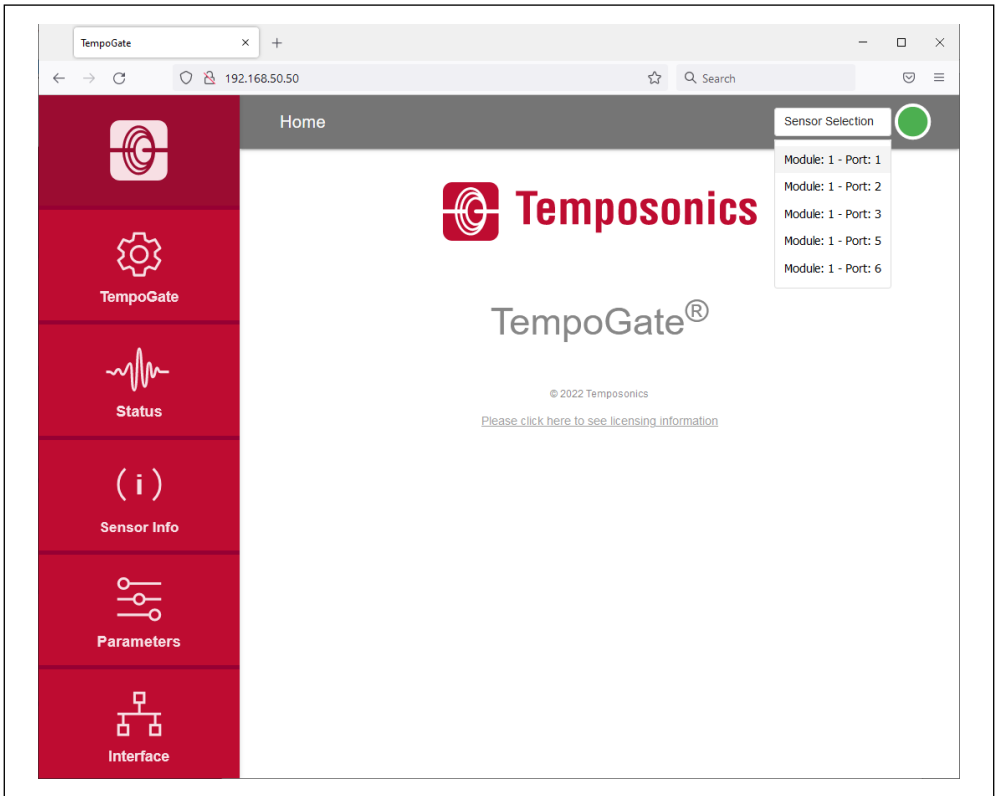

Fig. 27: Selecting a sensor via the drop down menu "Sensor Selection"

The connection icon in the top right shows the status of the connection between the TempoGate® smart assistant and the sensor (Fig. 28).



Connection status		
Green	Information	
 ON		Connection to sensor is established
Red	Information	
 ON		Connection to sensor is not established
Blue	Information	
 ON		Sensor in command mode

Fig. 28: Connection status

6.2 Menu item TempoGate

The menu item TempoGate includes information about the TempoGate® smart assistant like its serial number, firmware version and part number.

Changing the password for access the user interface

To change the password for accessing the user interface, click the CHANGE PASSWORD button (Fig. 29). The "Configure TempoGate" window opens. Enter the new password twice and confirm the change by clicking the SUBMIT button. If you click the CANCEL button, the change will be canceled.

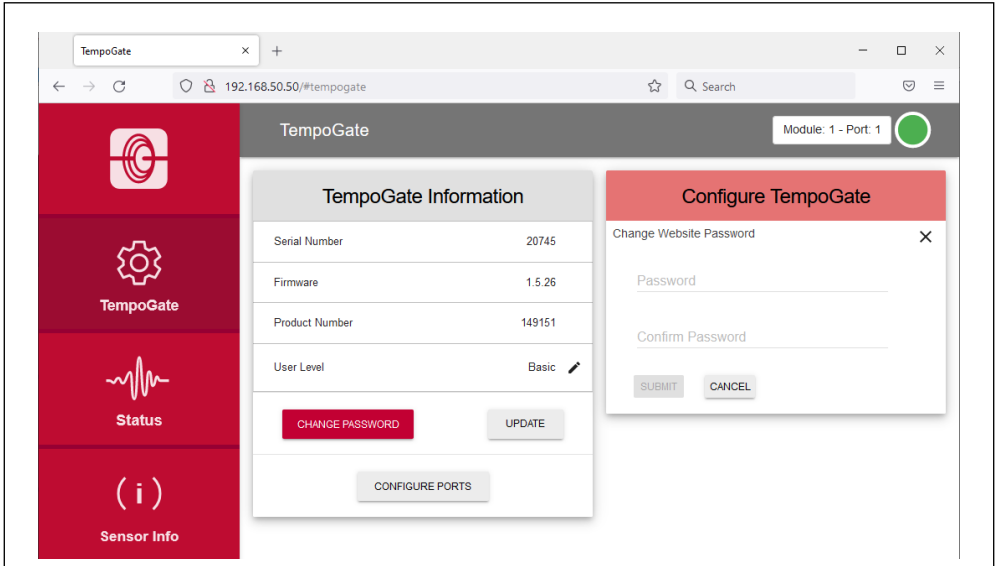

Fig. 29: Changing the password for access to the user interface

Changing the name of the ports

You can assign an individual name to the ports displayed in the "Sensor Selection" drop-down menu. To change the port names, click the CONFIGURE PORTS button (Fig. 30). The "Configure TempoGate" window opens. Click on a name and specify the new name. In Fig. 31, the name "Module 1 - Port 6" has been changed to "Cylinder 1". Confirm your change by clicking the SUBMIT button. By pressing the RESET button, the original name, in this case "Module 1 - Port 6", is displayed again. If you click the CANCEL button, the change will be canceled.

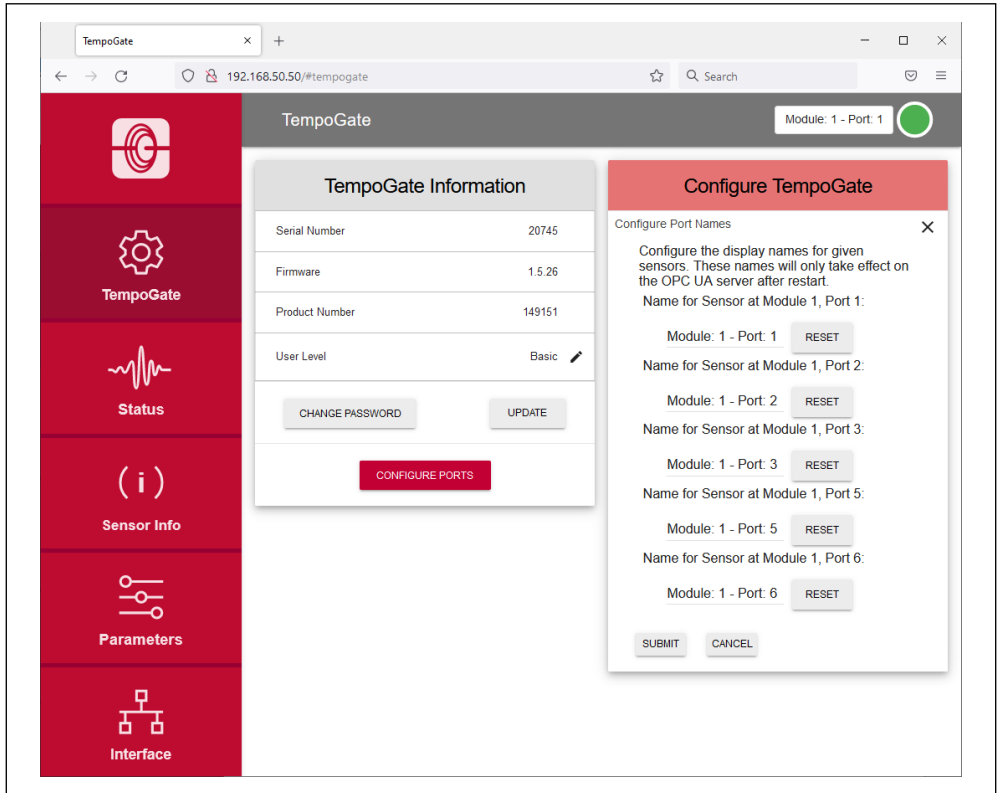

Fig. 30: Changing the name of the ports

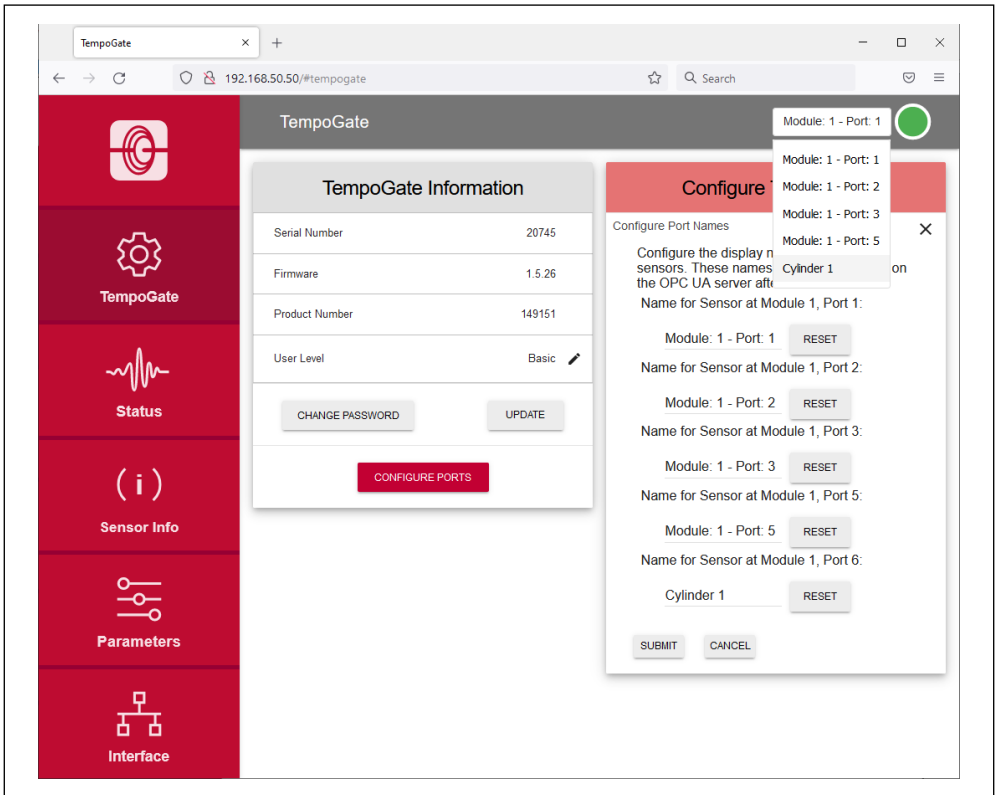

Fig. 31: Port name changed for Module 1 - Port 6

Updating the TempoGate® firmware

Firmware updates of the TempoGate® smart assistant are available for download from the Temposonics website www.temposonics.com/tempogate.

- Download the zip file and save it on your computer.
- Unzip the file.
- Connect your TempoGate® smart assistant to your computer via LAN or Wi-Fi. A firmware update is not possible when connecting via smartphone or tablet.
- Click the UPDATE button. The "Configure TempoGate" window opens (Fig. 32).
- Click the CHOOSE FILE button. Use the dialog to navigate to the location where you saved the firmware update file.
- Select the file "update.cjb". The selected file is displayed.
- Click the SUBMIT button to execute the update (Fig. 33).
- The update process of the firmware consists of two steps:
 1. Transferring the update file to the TempoGate® smart assistant. This step is visualized via the progress bar.
 2. Installing the firmware.
- After updating the firmware, this is indicated on the user interface by the message "Update Complete!" (Fig. 34).
- If you have connected your computer to the TempoGate® smart assistant via Wi-Fi, restore the Wi-Fi connection after the installation is complete. The Wi-Fi connection is interrupted during the update.
- Refresh your browser by clicking the key combination CTRL+F5 and use the TempoGate® smart assistant as usual.

Check regularly if a new firmware is available. Use the latest firmware. Firmware updates will improve the performance or add further features.

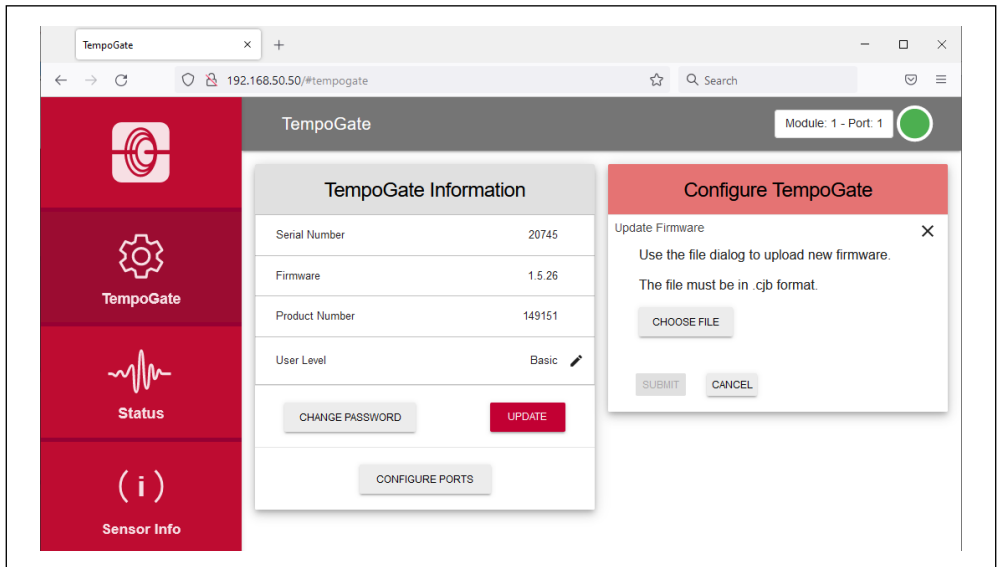

Fig. 32: The window "Configure TempoGate" to update the firmware

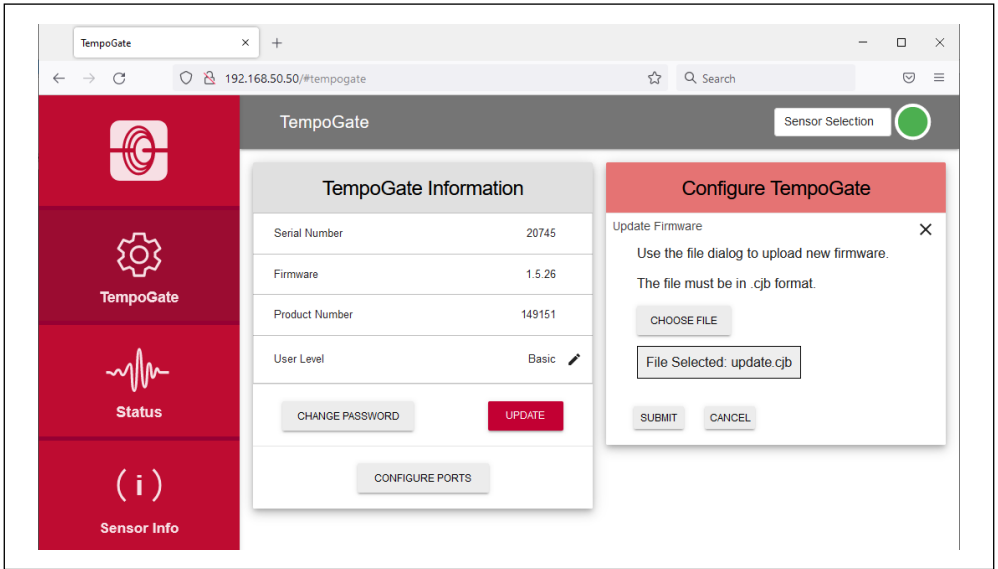

Fig. 33: Selected file for firmware update

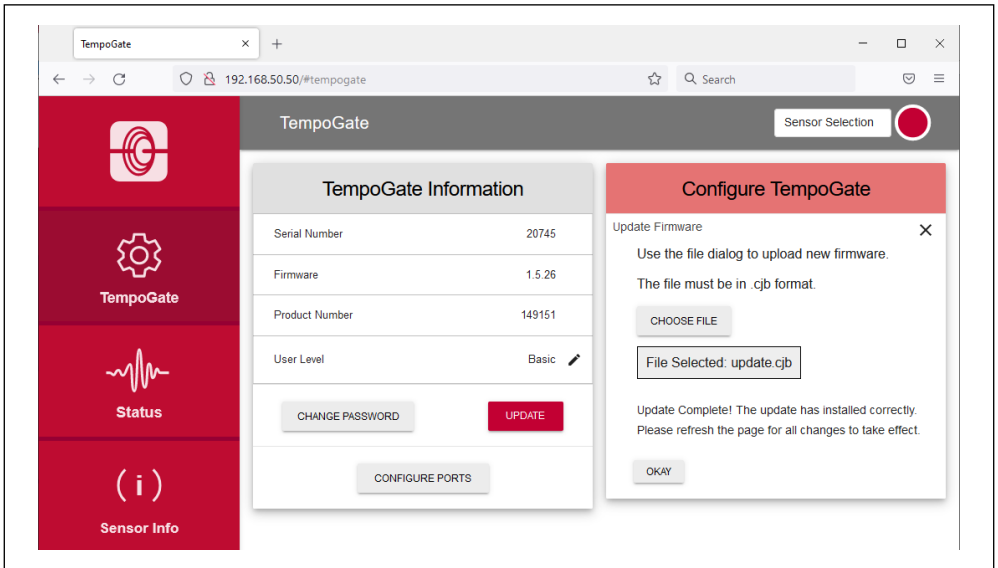

Fig. 34: Firmware update completed

6.3 Menu item Status

The status menu includes current information about the sensor (Fig. 35):

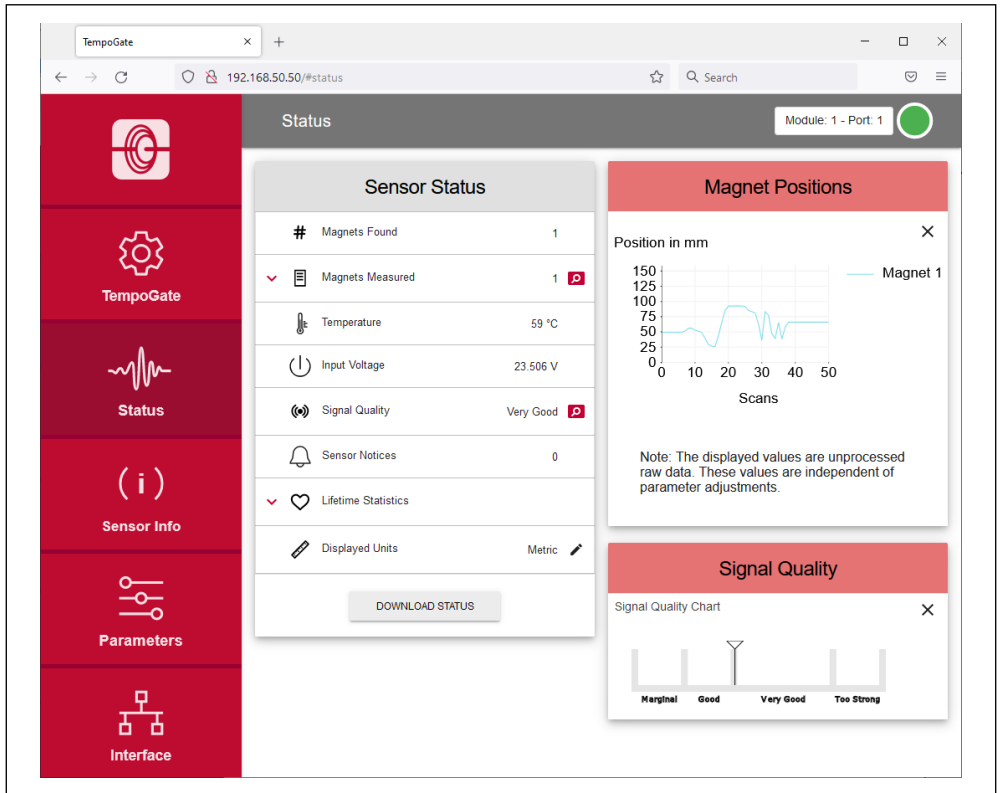

Fig. 35: Sensor status

- **Magnets Found:** Number of magnets detected on the sensor
- **Magnets Measured:** Number of set magnets. By clicking on the red arrow on the left the current position of the magnet is displayed. The magnifying glass on the right of the magnet provides a graphical display of the magnet's position (Fig. 35). Note, that the output of the position values for the graphical display is slower than the output of the position values to the controller.
- **Temperature:** Current temperature inside the sensor electronics housing.
- **Signal Quality:** The signal strength of the position magnet, judged in combination with the sensor, is reported in four levels (for a multi-position measurement, only the 1st magnet is taken into account):
 - **Marginal:** A position measurement can be performed, however incorrect results are possible.
 - **Good:** A position measurement can be performed reliably.
 - **Very Good:** A position measurement can be performed reliably.
 - **Too Strong:** Due to distortions incorrect results are possible when measuring the position.

The magnifying glass on the right of the magnet provides a graphical display of the signal quality (Fig. 35).

- **Input Voltage:** Current input voltage of the sensor.
- **Sensor Notices:** Current error messages.
- **User Statistics:** Depending on the firmware of the sensor status information is displayed which you can reset. By clicking the red arrow on the left the following information is displayed:
 - **Odometer:** Total distance travelled by the position magnet since last reset
 - **Magnet Cycles:** Total number of directional changes of the magnet since last reset
 - **Max Temperature:** Maximum temperature inside the sensor electronics housing reached so far since last reset
 - **Min Temperature:** Minimum temperature inside the sensor electronics housing reached so far since last reset

To reset these values, click on the black pencil in the line "User Statistics". The "Reset Statistics" window opens. Enter the word RESET and confirm by clicking SUBMIT. The values displayed under "User Statistics" are reset. If you click CANCEL, the reset will be canceled.

- **Lifetime Statistics:** By clicking the red arrow on the left information about the sensor statistics is displayed (depending on the connected sensor) (Fig. 36):
 - **Odometer:** Total distance travelled by the position magnet
 - **Magnet Cycles:** Total number of directional changes of the magnet since last reset
 - **Operational Time:** Total operational hours of the sensor
 - **Max Temperature:** Maximum temperature inside the sensor electronics housing reached so far
 - **Min Temperature:** Minimum temperature inside the sensor electronics housing reached so far
 - **Temperature Violations:** Duration of exceeding or falling below the permissible operating temperature range
 - **Max Voltage:** Maximum input voltage reached so far
 - **Min Voltage:** Minimum input voltage reached so far
 - **Voltage Violations:** Duration of exceeding or falling below the permissible power supply range
- **Displayed Units:** You can change the units of the displayed values from metric units to imperial units. To do this, click on the black pencil in this line. The "Change Display Units" window opens. Select the desired unit and confirm by clicking OK (Fig. 37).

NOTICE

The displayed values are unprocessed raw data. These values are independent of parameter adjustments.

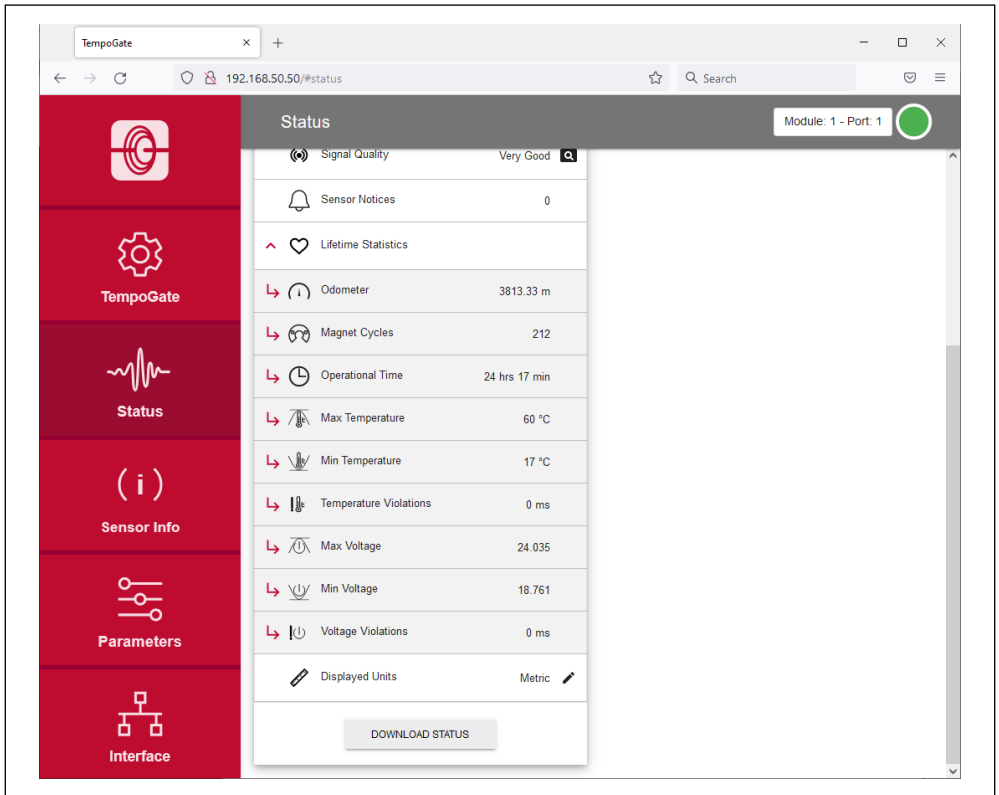

Fig. 36: Values under "Lifetime Statistics"

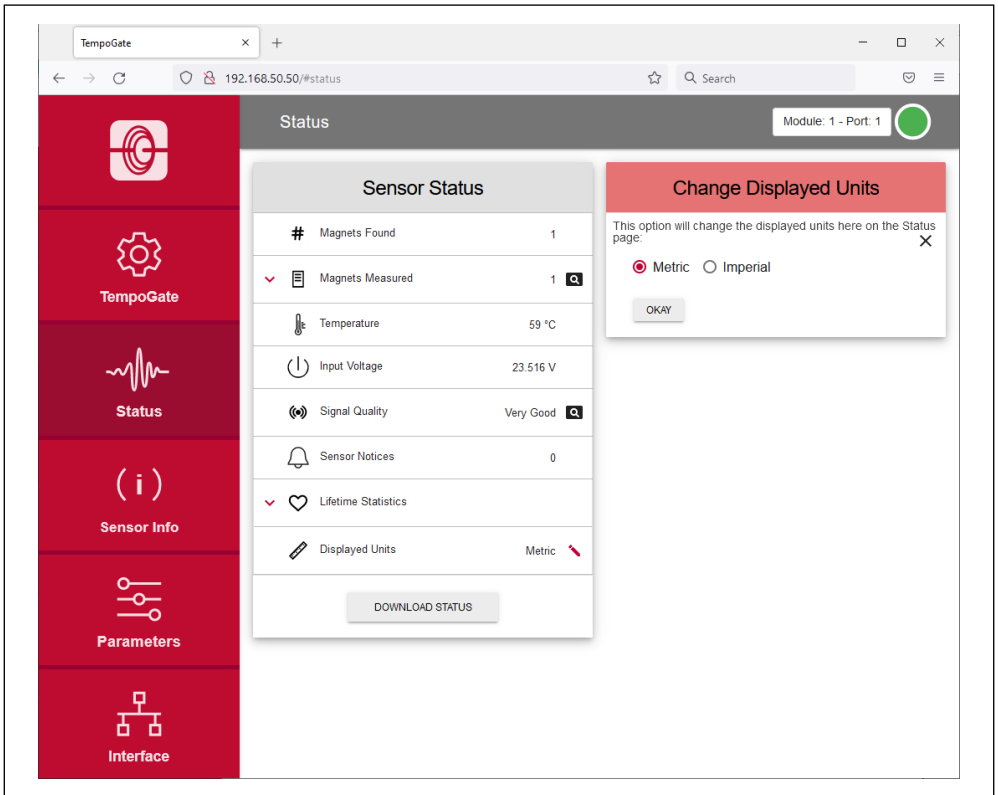

Fig. 37: Changing the display units

By clicking the **DOWNLOAD STATUS** button you can download the current status information of the sensor (Fig. 38). If you click the button, the "Download Status Data" window opens. Click **SUBMIT** to start the download. The file is saved on your computer according to your browser settings. You can send this file to us, e.g. in the event of an error, so we can better support you with the error analysis.

By clicking the **DOWNLOAD WAVEFORM** button you can download the graphical display of the position signal. If you click the button, the "Download Waveform Data" window opens. Enter the word **CONFIRM** and click **SUBMIT** to start the download. The file is saved on your computer according to your browser settings. You can send this file to us, e.g. in the event of an error, so we can better support you with the error analysis.

NOTICE
The generation of the graphical display of the position signal on the sensor briefly interrupts the normal operation of the sensor.

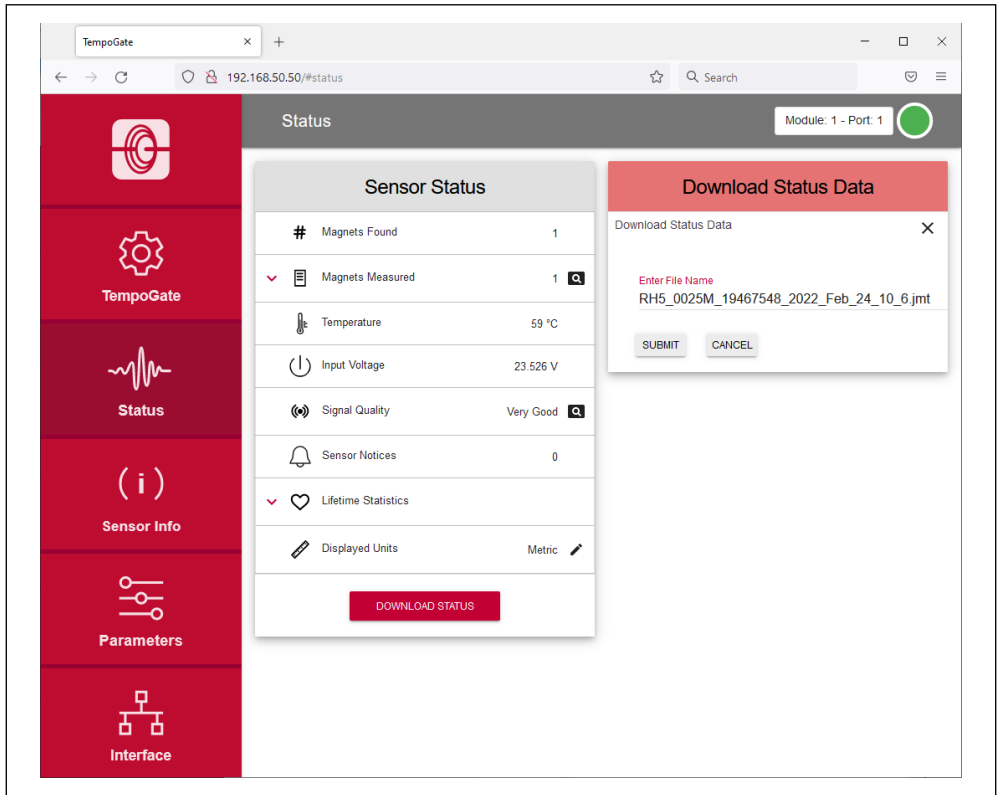

Fig. 38: Downloading status information

6.4 Menu item Sensor Info

The Sensor Info menu includes information about the connected sensor like stroke length, serial number and order code. The displayed information depends on the sensor output.

6.5 Menu item Parameters

The Parameter menu includes information about the operational settings of the connected sensor. The displayed parameters depend on the sensor output. Depending on the output, some parameters can only be read.

NOTICE

For information about the parameters, check the R-Series V operation manual of the sensor connected to your TempoGate® smart assistant.

To change parameters or to reset the sensor to factory settings, the command mode must be started. In command mode, the sensor does not output a position value. By clicking the button ENTER COMMAND MODE the "Enter Command Mode" window opens. After reading the information, enter the word COMMAND and confirm by clicking OK (Fig. 39).

After entering the command mode the connection icon on the top right will turn from green to blue. By clicking the button FACTORY RESET the sensor is reset to the factory setting. After the parameters have been configured or the factory reset has been carried out, click the button EXIT COMMAND MODE. The "Exit Command Mode" window for exiting the command mode will open. Click the button SAVE AND EXIT to exit the command mode and to transfer the changed parameters to the sensor (Fig. 40). If you click the button CANCEL, the changed parameters are not transferred to the sensor. In both cases the sensor returns to the normal function and outputs the current position value. The connection icon on the top right will turn to green.

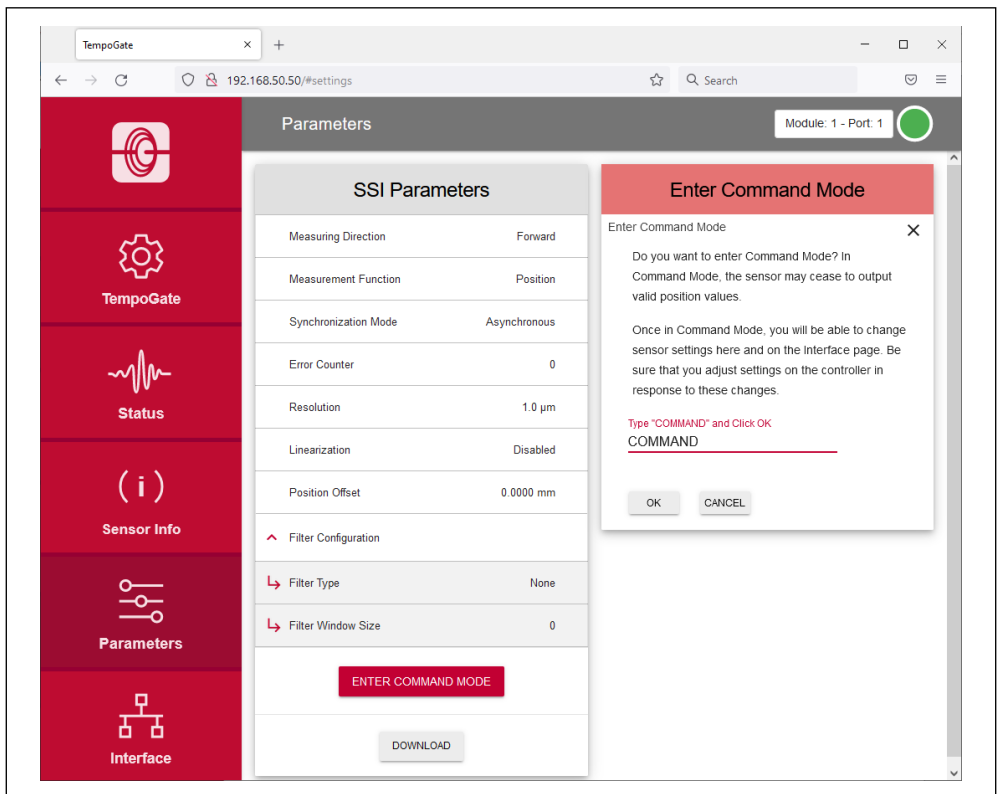

Fig. 39: Starting the "Command Mode"

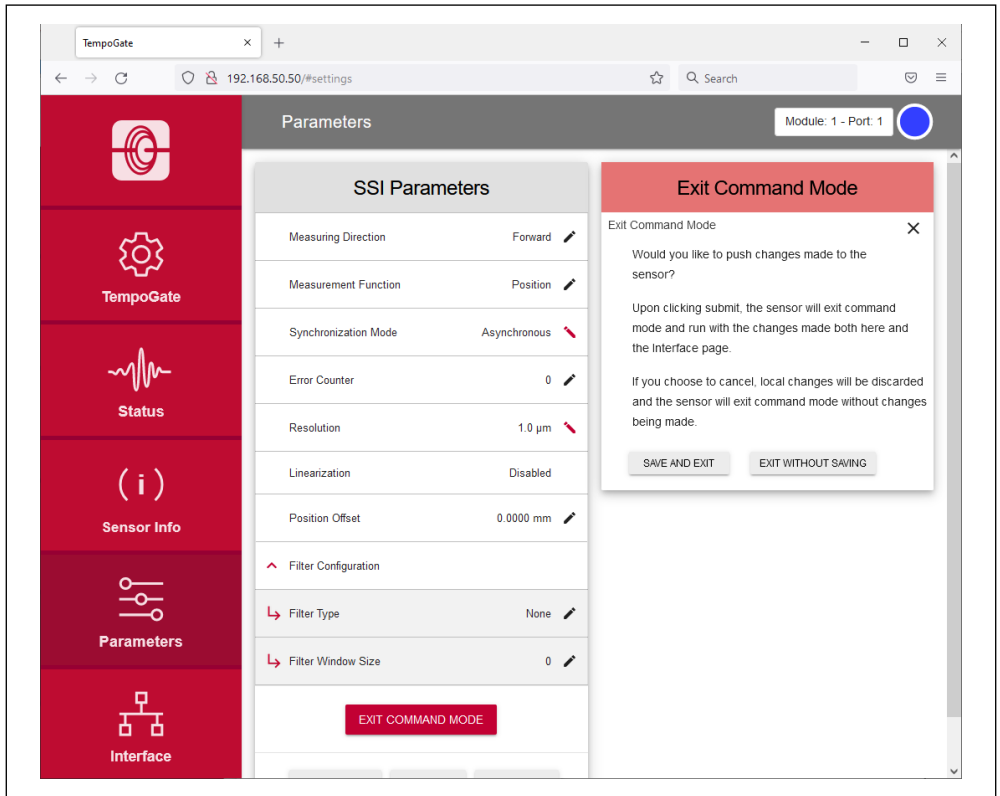

Fig. 40: Exiting the "Command Mode"

NOTICE

Do not enter the command mode and adjust parameters while the sensor is in operation.

6.6 Menu item interface

The interface menu includes information about the interface settings of the connected sensor. The displayed information depends on the sensor output. To change interface settings, the command mode must be started: See section 6.5 Menu item Parameters.

NOTICE

Do not enter the command mode and adjust parameters while the sensor is in operation.

7. Output data via OPC UA

The data displayed in the TempoGate® user interface can also be provided via OPC UA. In this example, the UaExpert is used to display the data via OPC UA. The TempoGate® smart assistant includes an OPC UA server. To connect a client such as UaExpert to the TempoGate® smart assistant OPC UA server, enter the IP address of the TempoGate® smart assistant with port 4840 for the address of the server.

- For the LAN connection, the URL of the TempoGate® smart assistant is: `opc.tcp://192.168.50.50:4840`
- For the WLAN connection, the URL when the TempoGate® smart assistant is delivered is: `opc.tcp://192.168.1.1:4840`

Fig. 41 shows the user interface of the UaExpert. As shown in the "Project" window on the left side of the screen, the UaExpert is connected to the TempoGate® OPC UA server. The objects of the TempoGate® smart assistant are listed in the "Address Space" window below. The connection modules and channels are displayed with the designation "Module: x - Port: y". If individual channel names have been assigned via the user interface of the TempoGate® smart assistant, these names are taken and displayed in the OPC UA client after a restart of the client.

In this example some objects of the sensor connected to connection module 1 at port 1 (Module: 1 - Port: 1) are expanded. The objects can be dragged from the "Address Space" window to the main "Data Access View" window. In this example, the objects "Order Code", "Serial Number" and "Operational Time" have been dragged into the main window so that the values of these objects are displayed.

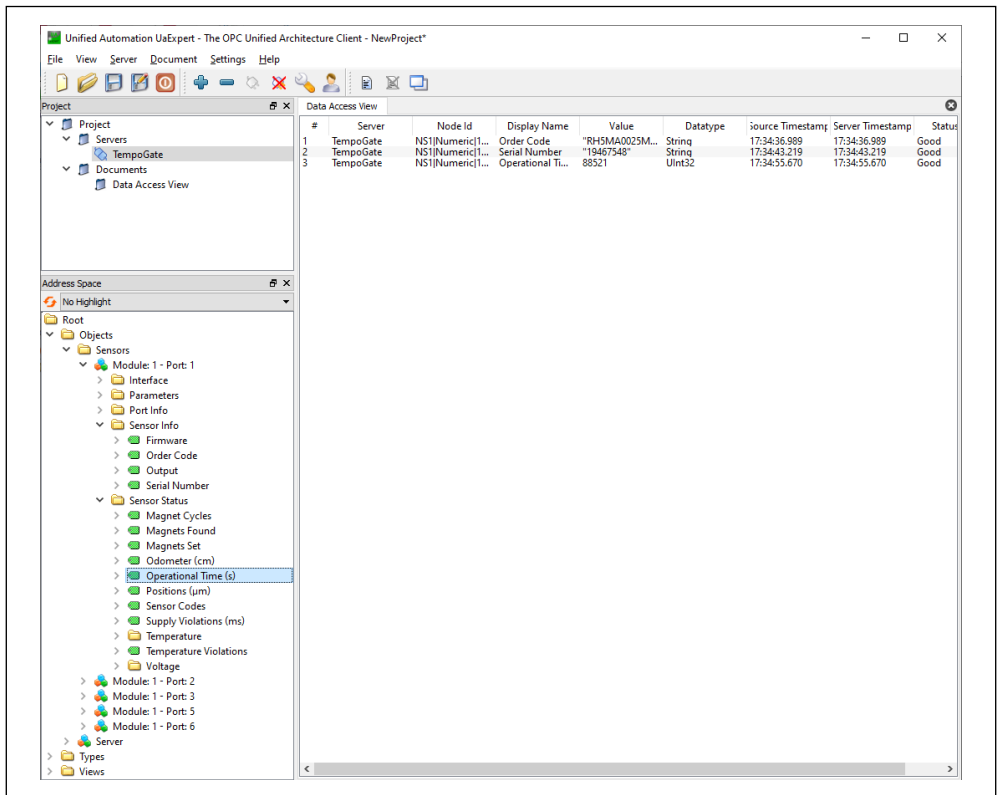

Fig. 41: User interface of UaExpert connected to the TempoGate® smart assistant

NOTICE

- The values of the objects can only be read via OPC UA and cannot be changed. To change parameter values or settings of the connected sensor, use the TempoGate® user interface via a LAN or Wi-Fi connection.
- The displayed position values are unprocessed raw data. These values are independent of parameter adjustments.

8. Recovery

The TempoGate® gateway can be restored using a USB stick with a signed image (part no. 531155-1). To perform a restore, proceed as follows:

- Switch off the TempoGate® smart assistant.
- Insert the USB stick with a signed image (part no. 531155-1) into one of the two USB ports on the TempoGate® gateway.
- Turn on the TempoGate® smart assistant.
- The signed software image is loaded to the gateway. This process takes about 5 minutes.
- Then switch off the TempoGate® smart assistant.
- Remove the USB stick.
- Turn on the TempoGate® smart assistant.
- The signed software image is installed. This process takes about 2 minutes.
- During the restore process, all settings are reset to the factory default. Adjust the settings.

9. Technical data

Operation conditions	
Operating temperature	-20...+60 °C (-4...140 °F)
Ingress protection	IP20
Vibration test	2g/10Hz...150Hz/2.5 h, DIN EN 60068-2-6
Shock test	15g/11ms, DIN EN 60068-2-27
EMC test	Immunity: EN61000-6-2, Emission: EN61000-6-3, FCC, ISED, RED
Design / Material	
Housing	Gateway: Metal Connection Module: Polyamide
Electrical connection	
Connection type	Gateway: 3 pin connection, 2 × USB, 1 × RJ45 Connection module: 4 × push-in per channel
Operating voltage	Gateway: 24 VDC (-15/+20 %) Connection module: +12...30VDC
Power consumption	0.2...1 W + power of the connected sensors
Polarity protection	Up to -36 VDC
Wi-Fi	
Wi-Fi standard	IEEE 802.11b/g/n
Frequency range	2.4 GHz: 2.412 GHz...2.472 GHz



Temposonics

AN AMPHENOL COMPANY

UNITED STATES 3001 Sheldon Drive
Temposonics, LLC Cary, N.C. 27513
Americas & APAC Region Phone: +1 919 677-0100
E-mail: info.us@temposonics.com

GERMANY Auf dem Schüttel 9
Temposonics 58513 Lüdenscheid
GmbH & Co. KG Phone: +49 2351 9587-0
EMEA Region & India E-mail: info.de@temposonics.com

ITALY Phone: +39 030 988 3319
Branch Office E-mail: info.it@temposonics.com

FRANCE Phone: +33 6 14 060 728
Branch Office E-mail: info.fr@temposonics.com

UK Phone: +44 79 21 83 05 86
Branch Office E-mail: info.uk@temposonics.com

SCANDINAVIA Phone: +46 70 29 91 281
Branch Office E-mail: info.sca@temposonics.com

CHINA Phone: +86 21 2415 1000/2415 1001
Branch Office E-mail: info.cn@temposonics.com

JAPAN Phone: +81 3 6416 1063
Branch Office E-mail: info.jp@temposonics.com

Document part number:
552087 Revision A (EN) 06/2022



temposonics.com

© 2022 Temposonics, LLC – all rights reserved. Temposonics, LLC and Temposonics GmbH & Co. KG are subsidiaries of Amphenol Corporation. Except for any third party marks for which attribution is provided herein, the company names and product names used in this document may be the registered trademarks or unregistered trademarks of Temposonics, LLC or Temposonics GmbH & Co. KG. Detailed trademark ownership information is available at www.temposonics.com/trademarkownership.