

C-Series H2-Sensor Analog

Temposonics® C-Series
Measuring Length 72...250 mm

Document Part No.
551397 Revision A

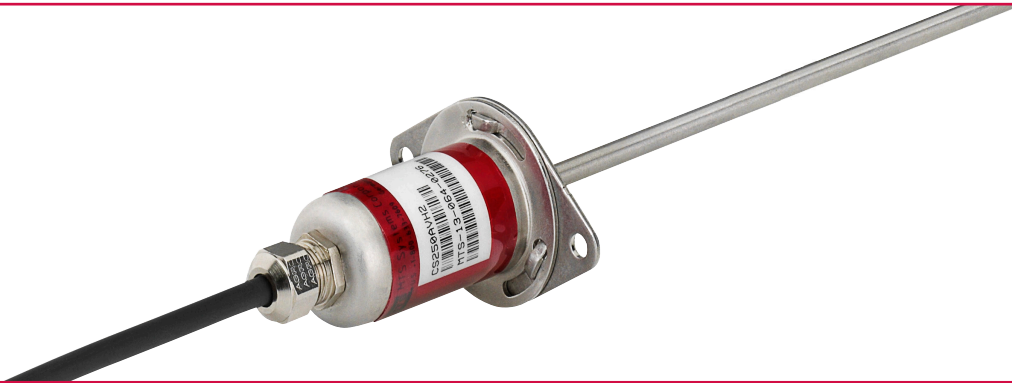

- Contactless measurement – entirely wear-free
- Low weight – ideal for small portable OEM products
- Cost-efficient
- Space-saving
- Low energy requirement – can be operated from 5 VDC or 12 VDC supply
- No need for periodic re-adjustment
- Available with various position magnets
- Optional: direct or inverse analog output signal
- Optional: assignment of output signal to measuring length

The sensor is a function of the customer requirements according to the application, and considering the environment, environmental influences, including EMC protection effects.

Measuring technology

For position measurement, the absolute, linear Temposonics® position sensors make use of the properties offered by the specially designed magnetostrictive waveguide. Inside the sensor a torsional strain pulse is induced in the waveguide by momentary interaction of two magnetic fields. One field is produced by a moving position magnet, which travels along the outside of the sensor rod, and the other field is generated by a current pulse applied to the waveguide. The interaction between these two magnetic fields produces a strain pulse, which is detected at the head of the sensor. The position of the moving magnet is determined precisely by measuring the time elapsed between the application of the current pulse and the arrival of the strain pulse. The result is a reliable position measurement system capable of ensuring accurate and repeatable measurement.

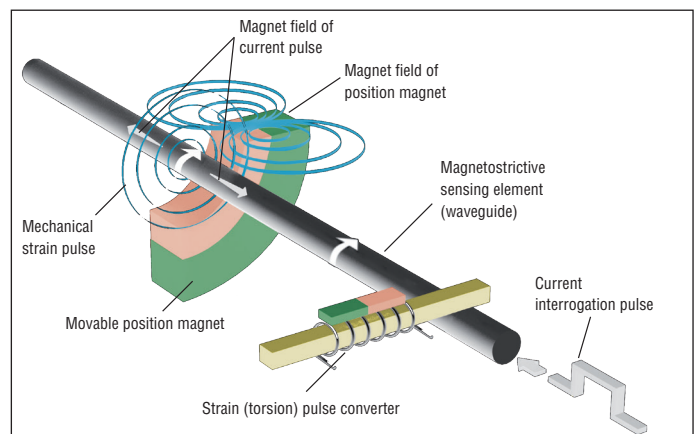

Technical data

Input

Measured value:	Position
Stroke length:	72, 109, 128, 148, 162, 186, 194, 217, 250 mm

Output

Voltage:	0.1 - 4.9 VDC
Resolution:	analog output signal
Signal without magnet:	not specified
Feature:	At 5 VDC operating voltage output is ratiometric to operating voltage

Accuracy

Linearity:	±0.15 mm by means of magnet 401842, between 5 % and 95 % of stroke length
Zero tolerance:	±1 mm
Hysteresis:	±25 µm
Repeatability:	±25 µm
Temperature coefficient:	±0.005 % per °C
Update time:	500 Hz (2 ms)

Operation conditions

Operating temperature:	-40 °C...+75 °C (+105 °C after consulting MTS)
Storage temperature:	-40 °C...+85 °C

Pressure

up to 2500 m altitude

IP Protection

IP67
 6 - DIN 40 050 Part 9 – Protection against foreign bodies: dustproof, complete protection against contact
 7 - DIN 40 050 Part 9 – Protection against water – Temporary immersion

Environmental testing

Shock test:	IEC-68-2-27 10 g (11ms) -> Single hit 10 g (11ms) 1000 shocks per axis
Vibration test:	IEC 60068-2-6 (10...2000 Hz) 10 g Sinus (resonance frequencies excluded)
EMC-test:	Electromagnetic emission EN 61000-6-4 CISPR 16-2-3 – Disturbance field strength (measuring distance 3 m) CISPR 16-2-1 – Disturbance current (DC voltage supply) Electromagnetic immunity EN 61000-6-2 EN 61000-4-2 – Electrostatic discharge (ESD) EN 61000-4-3 – Radiated electrosolenoidic radio frequency, free radiated EN 61000-4-4 – Electrical fast transient (Burst) EN 61000-4-5 – Surge EN 61000-4-6 – Conducted radio-frequency, line guided EN 61000-4-8 – Power frequency solenoidic field

The sensor is a function of the customer requirements according to the application, and considering the environment, environmental influences, including EMC protection effects.

Design, material

Housing:	Stainless steel 1.4404 (AISI 316L)
Protective tube:	Stainless steel 1.4404 (AISI 316L)

Electrical connection

Supply voltage:	CS: 5 VDC (tolerance range 4.75 - 5.5 VDC), CM: 12 VDC (tolerance range 9 - 15 VDC)
Max. power consumption:	max. 40 mA
Output load:	analog: > = 10 kΩ
Overvoltage protection:	CS: up to 19 VDC short term CM: up to 29 VDC short term
Polarity protection:	VDC - GND

Pin	Signal
White	DC Ground
Brown	Supply Voltage
Green	Output Signal
Silver	GND

Operating voltage quality:	Load control:	CS: 5 VDC ±0.1 %	CM: 12 VDC: ±0.15 %	for Ua at Ia 0 - 100 % for Ua at Uemin - Uemax
	Grid control:	±0.05 %	±0.05 %	
	Ripple:	< 50 mVpp	< 100 mVpp	

Mechanical connection

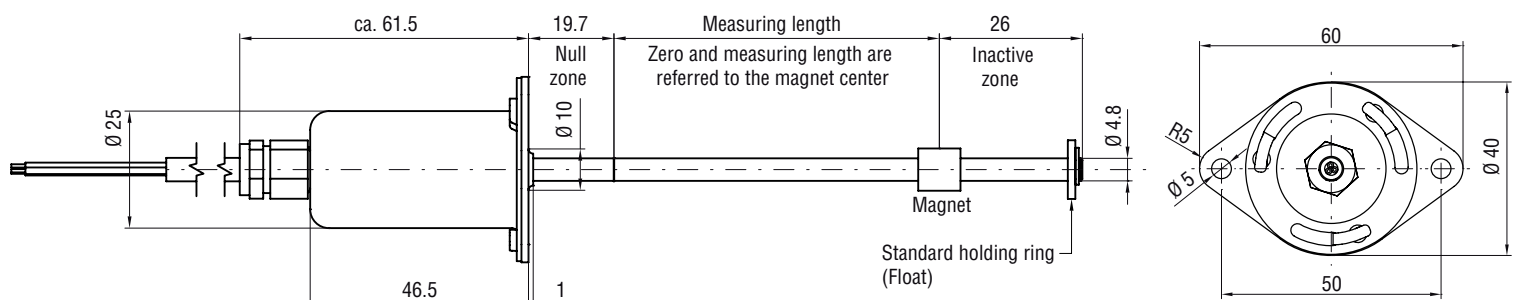

Accessories

Ring magnets

Description	Part no.	Inside Ø	Outside Ø	Width
Ring magnet 6.5 mm	401 842	6.5 mm	9 mm	9 mm
Ring magnet 19.3 mm	400 424	19.3 mm	28 mm	4.9 mm
Ring magnet 13.5 mm	254 012	13.5 mm	20 mm	10.5 mm

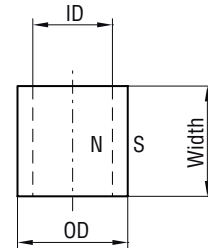

Float

Description	Part no.	Inside Ø	Outside Ø	Width
Float 1	201 611	9.5 mm	28.6 mm	30 mm
Float 2	201 656	6 mm	22 mm	33 mm

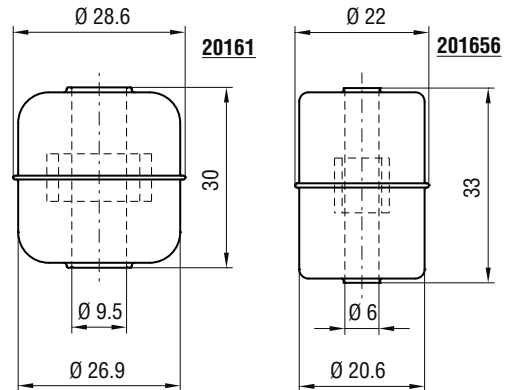

Temposonics® order code

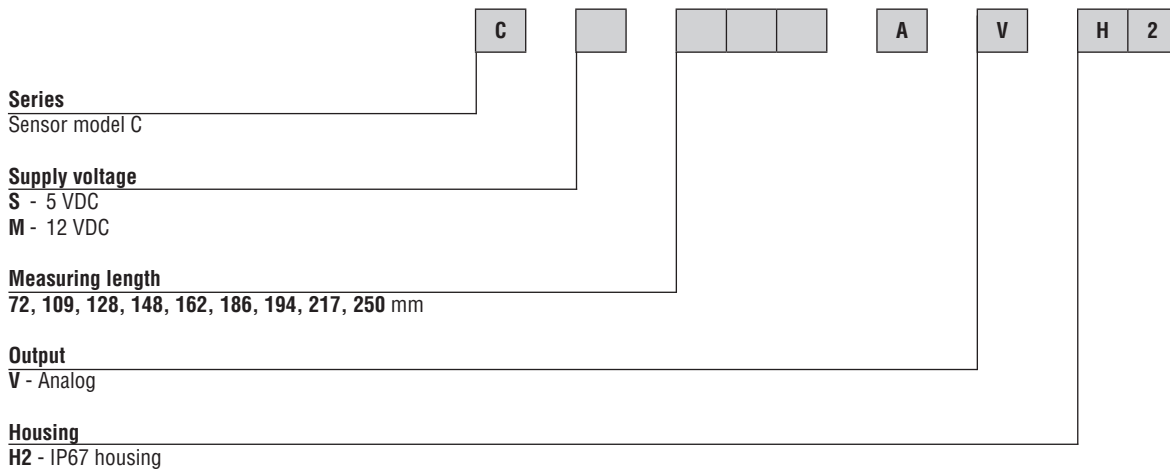

Example:
CM186AVH2 Sensor model C - Supply voltage 12 VDC - Measuring length 186 mm - Output analog - Housing IP67

Magnet and float options (An additional quantity of 1 unit per sensor should be ordered)

Description	Function	Article No.
Ring magnet 6.5 mm	standard	401 842
Ring magnet 19.3 mm	optional after approval for applications requiring a magnet with more clearance	400 424
Ring magnet 13.5 mm	optional after approval for applications requiring a magnet with more clearance	254 012
Float 1 with magnet	optional after approval for applications	201 611
Float 2 with magnet	optional after approval for applications	201 656

IP67 - Protection-kit

Description	Function	Article No.
Protection-kit	electronics housing, O-ring	253 525
Protective tube with flange	two-hole flange/order tube length with information - XXX	253 526-XXX

Application examples:

The target in customer solutions is a high degree of efficiency and synergy to the product. During the design phase measurements need to be taken which enable the product to meet customer requirements suitable for the application.

In this respect, close cooperative partnership between the customer and MTS is desirable.

All constructive measures relating to operating parameters (vibration, temperature and ESD) require consultation with MTS. This also includes the CE marking of components used for installation.



Level measurement in medical technology

An analyser for immunodiagnosics applications uses magnetostrictive level sensors in containers to monitor the levels of consumables and of the collected waste products of the analysis. Through continuous measurement, it is always known how much fluid is in the containers. This enables continuous reloading without interruption of the analysis and anticipatory planning.



Increased dosing accuracy, reduced consumption

The dosing accuracy during preparation of damping solution and precise control of the IPA concentration are of considerable importance for the production and process stability in printing systems. The continuous discussion relating to the toxic load of the ambient air at work places and the need for cost reduction in printing companies also requires further reduction of isopropyl alcohol in the damping solution. The Temposonics® OEM-sensor plays an important part for dosing of damping solutions and thus for decreasing the overall costs.



Position feedback in process measurement and control systems

The valve position feedback combines well-proven sensor technology and state-of-the-art design for optimized applications. Our development activity focused on the requirements and wishes expressed by our customers in the liquid processing industry.

In addition to safe control and monitoring of all functions of process valves in breweries, dairies, facilities for production of fruit juice and production plants in the pharmaceutical industry, the C-Series provides a high degree of efficiency.



Position feedback in steering systems

The customer-specific sensors are used to monitor the steering position of rear drives and to provide position feedback. Based on the linear C-series position sensor, these sensors are equipped with a special housing, which was developed by the end user and realized by MTS. The sensors measure the stroke of steering cylinders on the port side and the bow side. Typically installed in multi-engine boats, the boat control system uses the sensor signal to permit control of the boat movement using a joystick: A solution termed "Steer-By-Wire".



Cabin suspension

To reduce the human vibration, directive 2002/44/EC (human vibration directive) of the European Union has been implemented into national law in March 2007. This directive defines binding limit values (reference period of 8 hours < value 0.5 m/s²) for the hand-and-arm area as well as whole-body vibration values, which must not be exceeded.

These limit values are met by effectively reducing the induced vehicle vibration using C-series position sensors in a cabin suspension system. The cabin suspension system permits reduction of the accelerations mainly in the Z axis. Due to this reduction, the vibration load acting on the driver is alleviated considerably, without affecting driving experience and operability.

Document Number: 551397 Rev. A (EN) 04/2013

MTS and Temposonics® are registered trademarks of MTS Systems Corporation.

All other trademarks are the property of their respective owners.

Printed in Germany. Copyright © 2013 MTS Sensor Technologie GmbH & Co. KG. Alterations reserved.

All rights reserved in all media. No license of any intellectual property rights is granted.

The information is subject to change without notice and replaces all data sheets previously supplied.

The availability of components on the market is subject to considerable fluctuation and to accelerated technical progress.

Therefore we reserve the right to alter certain components of our products depending on their availability.

In the event that product approvals or other circumstances related to your application do not allow a change in components, a continuous supply with unaltered components must be agreed by specific contract.

www.mtssensor.com

MTS
SENSORS

**MTS Sensor Technologie
GmbH & Co. KG**
MTS Automotive Sensors GmbH
Auf dem Schüffel 9
58513 Lüdenscheid, Germany
Tel. + 49-23 51-95 87 0
Fax + 49-23 51-5 64 91
E-Mail: info@mtssensor.de
www.mtssensor.de

MTS Systems Corporation
Sensors Division
3001 Sheldon Drive
Cary, N.C. 27513, USA
Tel. + 1-919-677-0100
Fax + 1-919-677-0200
E-Mail: sensorsinfo@mts.com
www.mtssensors.com

MTS Sensors Technology Corp.
737 Aihara-cho,
Machida-shi, Japan
Tel. + 81-42-775-3838
Fax + 81-42-775-5516
E-Mail: info@mtssensor.co.jp
www.mtssensor.co.jp