

Temposonics®

Magnetostrictive Linear Position Sensors

RP Powerlink V2 Data Sheet

- Rugged industrial sensor
- For mounting on machines
- Diagnostics LEDs



MEASURING TECHNOLOGY

For position measurement, the absolute, linear Temposonics® position sensors make use of the properties offered by the specially designed magnetostrictive waveguide. Inside the sensor a torsional strain pulse is induced in the waveguide by momentary interaction of two magnetic fields. The interaction between these two magnetic fields produces a strain pulse, which is detected by the converter at the sensor electronics housing. One field is produced by a moving position magnet, which travels along the sensor rod with the waveguide inside. The other field is generated by a current pulse applied to the waveguide. The position of the moving magnet is determined precisely by measuring the time-of-flight between the application of the current pulse and the arrival of the strain pulse at the sensor electronics housing. The result is a reliable position measurement with high accuracy and repeatability.

RP SENSOR

Robust, non-contact and wear free, the Temposonics® linear position sensors provide best durability and accurate position measurement solutions in harsh industrial environments. The position measurement accuracy is tightly controlled by the quality of the waveguide which is manufactured by MTS Sensors. The position magnet is mounted on the moving machine part and travels contactlessly over the sensor sensing element with the built-in waveguide.

Temposonics® RP is a high-performance sensor for external mounting. The position magnet, mounted to the movable machine part, can either be an U-magnet or a captive-sliding magnet. The free magnets travel along the sensor profile with a defined distance. This kind of installation tolerates a lateral offset as well as a height offset. Therefore the robust sensor is very versatile. A superior performance for instance in plastic and rubber as well as in paper and wood processing industry is guaranteed.

POWERLINK V2 INTERFACE

Temposonics® position sensors fulfil the requirements of the Ethernet Powerlink Standardization Group (EPSG). Ethernet Powerlink V2 is an open protocol based on the Ethernet-standard according to IEEE 802.3. It is an extension to the Ethernet protocol which allows real-time data communication. Within the Ethernet Powerlink protocol a CANopen based communication protocol for user data is specified. Powerlink is the only Ethernet protocol that meets the high real-time requirements with a software-only concept. No special Powerlink hardware is needed.

Delivered information:

- Absolute position
- Velocity
- Status

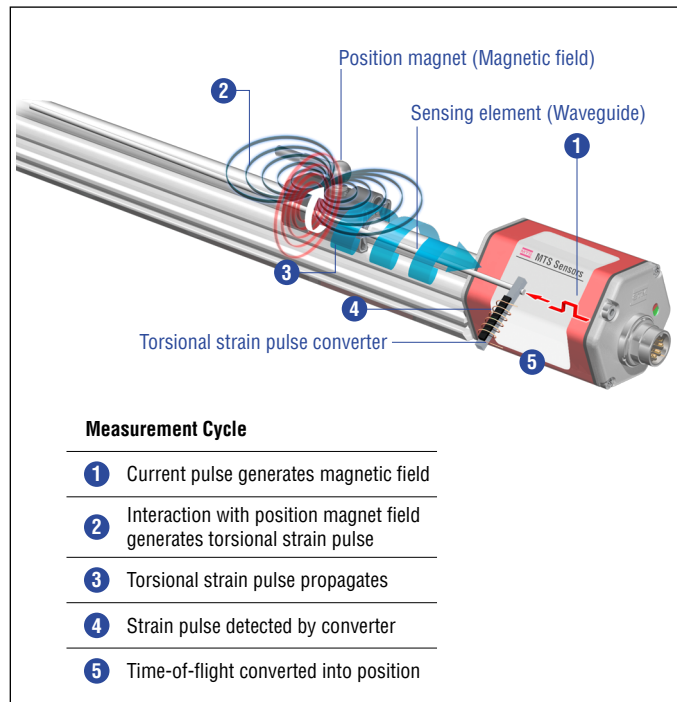

Fig. 1: Time-of-flight based magnetostrictive position sensing principle



Fig. 2: Typical application: Plastics processing

TECHNICAL DATA

Output				
Interface	Ethernet POWERLINK			
Data protocol	POWERLINK V2 according to IEEE 802.3			
Measured value	Position, velocity / option: Multi-position measurement (2...4 positions) ¹			
Measurement parameters				
Resolution	1 µm, 2 µm, 5 µm, 10 µm, 50 µm or 100 µm (selectable)			
Cycle time	Stroke length	up to 2400 mm	up to 4800 mm	up to 5080 mm
	Cycle time	1.0 ms	2.0 ms	4.0 ms
Linearity ²	< ±0.01 % F.S. (minimum ±50 µm)			
Repeatability	< ±0.001 % F.S. (minimum ±2.5 µm) typical			
Hysteresis	< 4 µm typical			
Temperature coefficient	< 15 ppm/K typical			
Operating conditions				
Operating temperature	-40...+75 °C (-40...+167 °F)			
Humidity	90 % relative humidity, no condensation			
Ingress protection ³	IP65 (correctly fitted)			
Shock test	100 g (single shock), IEC standard 60068-2-27			
Vibration test	15 g / 10...2000 Hz, IEC standard 60068-2-6 (excluding resonant frequencies)			
EMC test	Electromagnetic emission according to EN 61000-6-3 Electromagnetic immunity according to EN 61000-6-2 The sensor meets the requirements of the EU directives and is marked with CE			
Magnet movement velocity	Magnet slider: Maximum 10 m/s; U-magnet: Any; block magnet: Any			
Design / Material				
Sensor electronics housing	Aluminum			
Sensor profile	Aluminum			
Stroke length	25...5080 mm (1...200 in.)			
Mechanical mounting				
Mounting position	Any			
Mounting instruction	Please consult the technical drawings and the operation manual (document number: 551657)			
Electrical connection				
Connection type	2 × M12 female connector (5 pin), 1 × M8 male connector (4 pin)			
Operating voltage ⁴	+24 VDC (-15 / +20 %); UL recognition requires an approved power supply with energy limitation (UL 61010-1), or Class 2 rating according to the National Electrical Code (USA) / Canadian Electrical Code.			
Ripple	≤ 0.28 V _{pp}			
Current consumption ⁴	110 mA typical			
Dielectric strength	500 VDC (DC ground to machine ground)			
Polarity protection	Up to -30 VDC			
Overvoltage protection	Up to 36 VDC			

1/ The number of magnets depends on the stroke length

2/ With position magnet # 252182

3/ The IP rating is not part of the UL approval

4/ Power supply must be able to provide current of 1A for power up process

TECHNICAL DRAWING

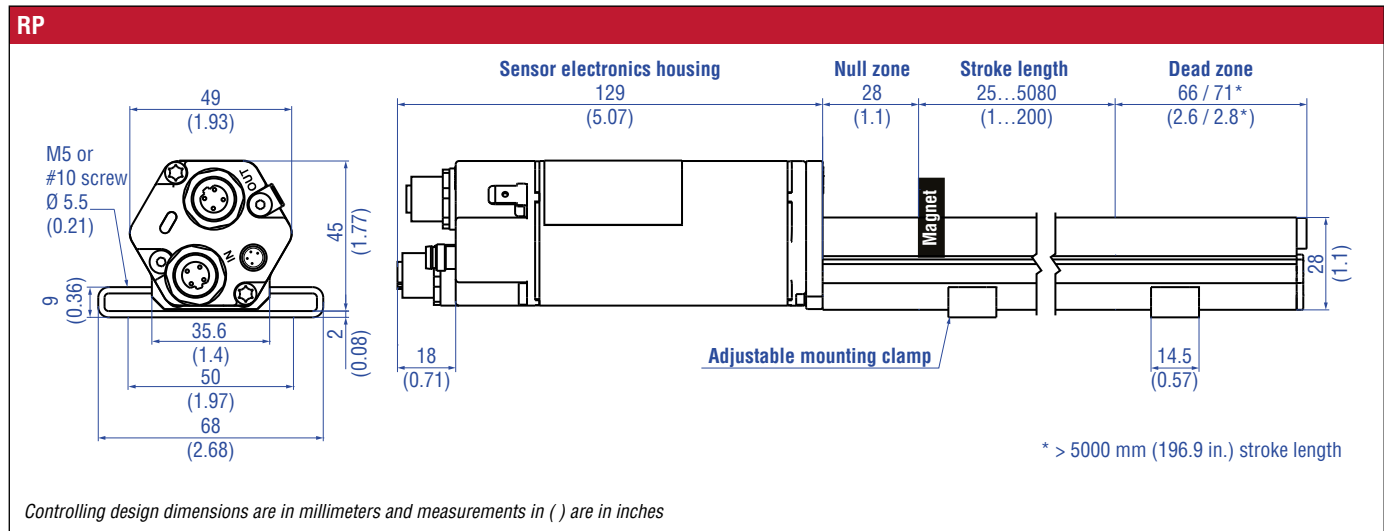



Fig. 3: Temposonics® RP with U-magnet

CONNECTOR WIRINGS



D56		
Signal		
M12 female connector (D-coded)	Pin	Function
<p>View on sensor</p>	1	Tx (+)
	2	Rx (+)
	3	Tx (-)
	4	Rx (-)
	5	Not connected
M12 female connector (D-coded)	Pin	Function
<p>View on sensor</p>	1	Tx (+)
	2	Rx (+)
	3	Tx (-)
	4	Rx (-)
	5	Not connected
Power supply		
M8 male connector	Pin	Function
<p>View on sensor</p>	1	+24 VDC (-15 / +20 %)
	2	Not connected
	3	DC Ground (0 V)
	4	Not connected

Fig. 4: Connector wirings D56

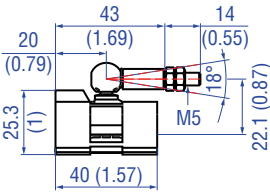
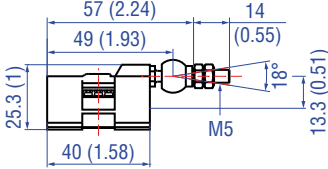
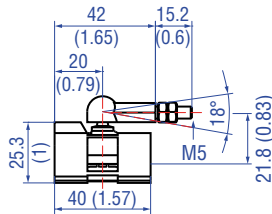
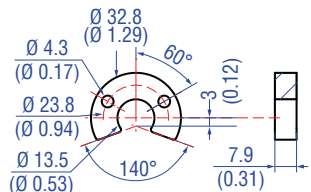
FREQUENTLY ORDERED ACCESSORIES – Additional options available in our [Accessories Guide](#)  551444

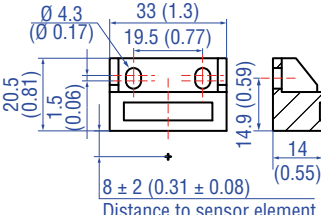
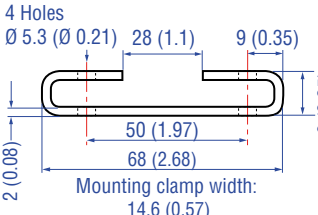
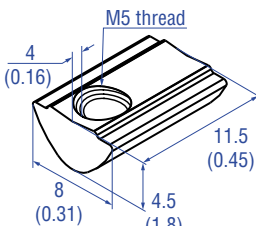
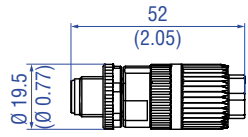
Position magnets			
			
<p>Magnet slider S, joint at top Part no. 252 182</p>	<p>Magnet slider V, joint at front Part no. 252 184</p>	<p>Magnet slider G, backlash free Part no. 253 421</p>	<p>U-magnet OD33 Part no. 251 416-2</p>
<p>Material: GRP, magnet hard ferrite Weight: Approx. 35 g Operating temperature: -40...+75 °C (-40...+167 °F)</p>	<p>Material: GRP, magnet hard ferrite Weight: Approx. 35 g Operating temperature: -40...+75 °C (-40...+167 °F)</p>	<p>Material: GRP, magnet hard ferrite Weight: Approx. 25 g Operating temperature: -40...+75 °C (-40...+167 °F)</p>	<p>Material: PA ferrite GF20 Weight: Approx. 11 g Surface pressure: Max. 40 N/mm² Fastening torque for M4 screws: 1 Nm Operating temperature: -40...+105 °C (-40...+221 °F)</p>

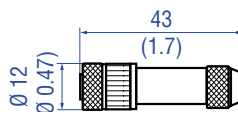
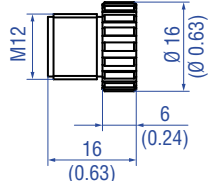
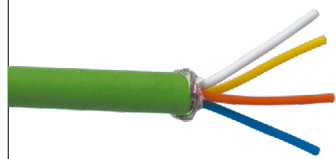
Position magnet	Mounting accessories	Cable connector *	
			
<p>Block magnet L Part no. 403 448</p> <p>Material: Hard ferrite Weight: Approx. 20 g Fastening torque for M4 screws: 1 Nm Operating temperature: -40...+75 °C (-40...+167 °F)</p> <p>This magnet may influence the sensor performance specifications for some applications.</p>	<p>Mounting clamp Part no. 400 802</p> <p>Material: Stainless steel (AISI 304)</p>	<p>T-nut Part no. 401 602</p> <p>Fastening torque for M5 screw: 4.5 Nm</p>	<p>M12 D-coded male connector (4 pin), straight Part no. 370 523</p> <p>Material: Zinc nickel-plated Termination: Insulation-displacement Cable Ø: 5.5...7.2 mm (0.2...0.28 in.) Wire: 24 AWG – 22 AWG Operating temperature: -25...+85 °C (-13...+185 °F) Ingress protection: IP65 / IP67 (correctly fitted) Fastening torque: 0.6 Nm</p>

Cable connectors *	Cables		
			
<p>M8 female connector (4 pin), straight Part no. 370 504</p> <p>Material: CuZn nickel plated Termination: Solder Cable Ø: 3.5...5 mm (0.14...0.28 in.) Wire: 0.25 mm² Operating temperature: -40...+85 °C (-40...+185 °F) Ingress protection: IP67 (correctly fitted) Fastening torque: 0.5 Nm</p>	<p>M12 connector end cap Part no. 370 537</p> <p>Female connectors M12 should be covered by this protective cap Material: Brass nickel-plated Ingress protection: IP67 (correctly fitted) Fastening torque: 0.39...0.49 Nm</p>	<p>PUR cable Part no. 530 125</p> <p>Material: PUR jacket; green Features: Cat 5, highly flexible Cable Ø: 6.5 mm (0.26 in.) Cross section: 2 × 2 × 0.35 mm² (22/7 AWG) Operating temperature: -20...+60 °C (-4...+140 °F)</p>	<p>PVC cable Part no. 530 108</p> <p>Material: PVC jacket; gray Features: Shielded, flexible Cable Ø: 4.9 mm (0.19 in.) Cross section: 3 × 0.34 mm² Operating temperature: -30...+80 °C (-22...+176 °F)</p>

NOTICE
* Follow the manufacturer's mounting instructions

Cables



**Cable with M12 D-coded male connector (4 pin), straight – M12 D-coded, male connector (4 pin), straight
Part no. 530 064**

Material: PUR jacket; green
Features: Cat 5e
Cable length: 5 m (16.4 ft)
Cable Ø: 6.5 mm (0.26 in.)
Ingress protection: IP65, IP67, IP68 (correctly fitted)
Operating temperature: -30...+70 °C (-22...+158 °F)



**Cable with M12 D-coded male connector (4 pin), straight – RJ45 male connector, straight
Part no. 530 065**

Material: PUR jacket; green
Features: Cat 5e
Cable length: 5 m (16.4 ft)
Cable Ø: 6.5 mm (0.26 in.)
Ingress protection M12 connector: IP67 (correctly fitted)
Ingress protection RJ45 connector: IP20 (correctly fitted)
Operating temperature: -30...+70 °C (-22...+158 °F)

ORDER CODE

1	2	3	4	5	6	7	8	9	10	11	12	13	14	15	16	17	18	19
R	P							D	5	6	1	U	3	0	1			
a		b	c					d			e	f				g optional		

a	Sensor model
R	P Profile

b	Design
G	Magnet slider, joint on top, backlash free (part no. 253 421)
M	U-magnet, OD33 (part no. 251 416-2)
S	Magnet slider, joint on top (part no. 252 182)
V	Magnet slider, joint at front (part no. 252 184)

c	Stroke length				
X	X	X	X	M	0025...5080 mm
Standard stroke length (mm)*		Ordering steps			
25... 500 mm		25 mm			
500...2500 mm		50 mm			
2500...5080 mm		100 mm			
X	X	X	X	U	001.0...200.0 in.
Standard stroke length (in.)*		Ordering steps			
1... 20 in.		1.0 in.			
20...100 in.		2.0 in.			
100...200 in.		4.0 in.			

d	Connection type
D	5 6 2 × M12 female connectors (5 pin), 1 × M8 male connector (4 pin)

e	Operating voltage
1	+24 VDC (-15 / +20 %)

f	Output
U	3 0 1 Powerlink V2

Optional:

g	Magnet number for multi-position measurement⁵
Z	0 2 2 magnets
Z	0 3 3 magnets
Z	0 4 4 magnets

NOTICE

Use magnets of the same type for multi-position measurement, e.g. 2 × U-magnets (part no. 251 416-2).

DELIVERY



- Sensor
- Position magnet
- 2 mounting clamps up to 1250 mm (49 in.) + 1 clamp for each 500 mm (20 in.)

Accessories have to be ordered separately

* / Non standard stroke lengths are available; must be encoded in 5 mm / 0.1 in. increments
5/ Note: Specify magnet numbers for your sensing application and order separately

UNITED STATES 3001 Sheldon Drive
MTS Systems Corporation Cary, N.C. 27513
Sensors Division Phone: +1 919 677-0100
E-mail: info.us@mtssensors.com

GERMANY Auf dem Schüffel 9
MTS Sensor Technologie 58513 Lüdenscheid
GmbH & Co. KG Phone: +49 2351 9587-0
E-mail: info.de@mtssensors.com

ITALY Phone: +39 030 988 3819
Branch Office E-mail: info.it@mtssensors.com

FRANCE Phone: +33 1 58 4390-28
Branch Office E-mail: info.fr@mtssensors.com

GREAT BRITAIN Phone: +44 79 44 15 03 00
Branch Office E-mail: info.uk@mtssensors.com

CHINA Phone: +86 21 6485 5800
Branch Office E-mail: info.cn@mtssensors.com

JAPAN Phone: +81 3 6416 1063
Branch Office E-mail: info.jp@mtssensors.com

Document Part Number:
551785 Revision B (EN) 08/2018



www.mtssensors.com