

Temposonics®

Magnetostrictive, Absolute, Non-contact
Linear-Position Sensors



E-Series Model EP2 Digital-Pulse (Start/Stop) Output

Document Part Number
551064 Revision C

Data Sheet



Model EP2 profile-style position sensor
with single-position measurement

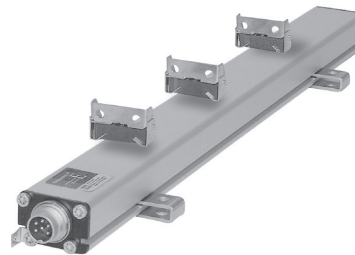

Model EP2 profile-style position sensor
with multiple-position measurement

FEATURES

- Linear, Absolute Measurement
- Non-Contact Sensing Technology
- Non-Linearity Less Than 0.02%
- Repeatability Within 0.001%
- Digital Position Output: Start/Stop Pulse
- EMI Shielded and CE Certified
- One Year Warranty

BENEFITS

- Economically Priced Magnetostrictive Sensor Technology
- Simultaneous multi-position Measurement
- Simple Sensor Parameter Upload
- Magnet is Secured to Moving Machine Part to 'Float' over the Sensor Housing
- Sensors Can Be Purchased Factory Direct From The MTS *Online Store*

APPLICATIONS

- Continuous Operation in Harsh Industrial Conditions
- Plastic Injection and Blow Molding
- Cutting, Drilling, Punching, Pressing and Bending
- Product Fabrication and Assembly

TYPICAL INDUSTRIES

- Plastics Molding and Processing
- Material Handling and Packaging
- Factory Automation
- Woodworking and Metalworking

Time-based Magnetostrictive position sensing principle

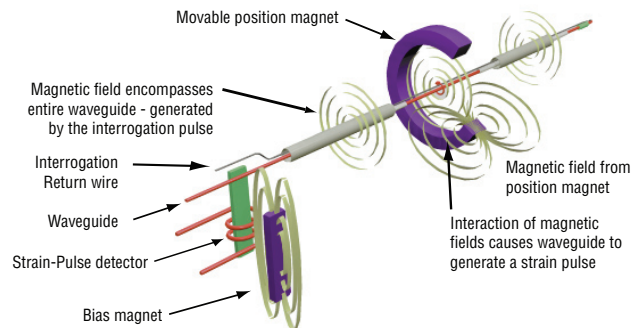

Benefits of Magnetostriction

Temposonics linear-position sensors use the time-based magnetostrictive position sensing principle developed by MTS. Within the sensing element, a sonic-strain pulse is induced in a specially designed magnetostrictive waveguide by the momentary interaction of two magnetic fields. One field comes from a moveable permanent magnet that passes along the outside of the sensor. The other field comes from an "interrogation" current pulse applied along the waveguide. The resulting strain pulse travels at sonic speed along the waveguide and is detected at the head of the sensing element.

The position of the magnet is determined with high precision and speed by accurately measuring the elapsed time between the application of the interrogation pulse and the arrival of the resulting strain pulse with a high-speed counter. The elapsed time measurement is directly proportional to the position of the permanent magnet and is an absolute value. Therefore, the sensor's output signal corresponds to absolute position, instead of incremental, and never requires recalibration or re-homing after a power loss. Absolute, non-contact sensing eliminates wear, and guarantees the best durability and output repeatability.

All specifications are subject to change. Contact MTS for specifications and engineering drawings that are critical to your application. Drawings contained in this document are for reference only. Go to <http://www.mtssensors.com> for the latest support documentation and related media.

Product overview

MTS Sensors continues to establish new performance standards for low-cost, fully-industrial, durable position sensors using the widely preferred magnetostrictive technology. This principle for accurate and non-contact measurement of linear-position sensing was developed 30 years ago by MTS and is used with outstanding success in a large variety of industrial applications.

E-Series Model EP2 sensors with digital-pulse (start/stop) output, can be ordered from the MTS **Online Store** at <http://www.mtssensorsstore.com>

Product specifications

Parameters	Specifications
OUTPUT	
Measured output variables:	Position; single or multi-position measurements
Resolution:	0.1, 0.01 and 0.005 mm (controller dependent)
Non-linearity:	< ± 0.02% full stroke (minimum ± 60 µm)
Repeatability:	< ± 0.001% full stroke (minimum ± 2.5 µm)
Output:	Digital-pulse (start/stop): RS-422 differential signal Serial parameter upload available for: measuring range, offset, gradient and status.
Position measurement:	Measurement Stroke lengths: 4, 6, 9, 12, 15, 18, 21, 24, 30, 36, 42, 48, 54 and 60 inches Contact factory for custom stroke lengths Update frequency: Controller dependent
ELECTRONICS	
Operating voltage:	+24 Vdc nominal: -15% or +20% Polarity protection: up to -30 Vdc Overvoltage protection: up to 36 Vdc Current drain: Start/Stop, 50 - 100 mA (Stroke length dependent) Dielectric withstand voltage: 500 Vdc (DC ground to machine ground)

Parameters	Specifications
ENVIRONMENTAL	
Operating conditions:	Operating temperature: -40 °C (-40 °F) to 75 °C (167 °F) Relative humidity: 90% no condensation
EMC test:	Emissions: IEC/EN 50081-1 Immunity: IEC/EN 50082-2 IEC/EN 61000-4-2/3/4/6, criterium A, CE qualified
Shock rating:	50 g (single hit)/ IEC standard 60068-2-27 (survivability)
Vibration rating:	5 g/10 to 2000 Hz, IEC standard 60068-2-6 (operational)
Wiring	
Connection type:	6-pin DIN (M16) male D60 connector
PROFILE STYLE SENSOR (MODEL EP2)	
Sealing:	IP 67
Sensor extrusion:	Aluminum
Mounting:	Any orientation. Adjustable mounting feet.
Magnet type:	Block magnet with stamped metal carrier

Output

The Temposonics E-Series Model EP2 digital-pulse (start/stop) output sensor requires a start signal from a controller or interface module to initiate the measurement cycle. The sensor generates a stop signal at the end of the measurement cycle that is used to stop the controller's counter clock. The elapsed time between the Start and Stop signals is directly proportional to the magnet's position along the active stroke length. The controller can calculate the absolute position of the magnet from the time value and the sensor's unique gradient value (inverse of the speed for the sonic pulse traveling in the sensor's waveguide). (see 'Figure 1').

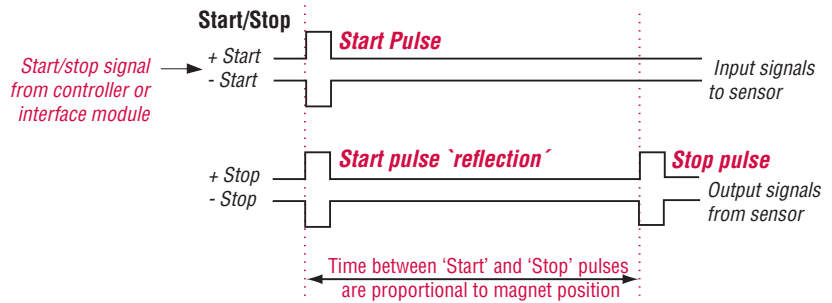

Figure 1. Stop/start output signals (RS-422 differential pairs)

Communication and programmability

SENSOR PARAMETER UPLOAD FEATURE

For applications using smart sensor interfaces, the E-Series Model EP2 with digital-pulse output comes with the ability to perform sensor parameter uploads. This feature replaces the manual task of entering sensor data saving time and preventing possible entry errors during start-up, or for system maintenance.

The upload feature supports the following sensor parameters:

- Measuring range
- Offset
- Gradient (Inverse speed of sensing pulse)
- Status

The sensor's specific parameters can be retrieved by the controller/interface module at any time, via the sensor's start/stop signal lines.

The sensor parameter upload feature requires a customer supplied RS-422 interface. The data format is serial, 4800 Baud, 8-bit data length. Please contact the factory for additional parameter upload protocol details.

Multi-position measurement

The Model EP2 digital-pulse output sensor provides multi-position measurements when used with more than one position magnet, and an appropriate controller/interface module. The minimum allowed distance between magnets is 3.0 in. (76 mm) to maintain proper sensor output. The total number of magnets is limited by the EP2 stroke length, and the interface module/controller that is used.

Model EP2 profile-style sensor digital-pulse (start/stop) output dimension references

MODEL EP2, PROFILE-STYLE SENSOR WITH BLOCK, STYLE L MAGNET

Drawing is for reference only, contact applications engineering for tolerance specific information.

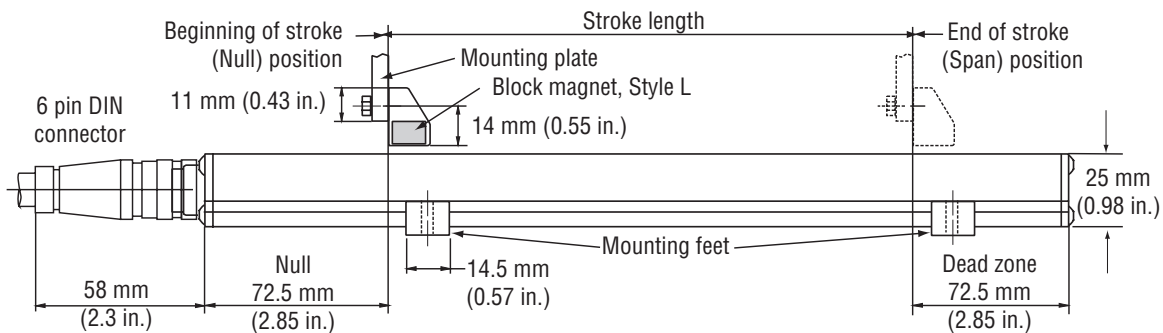

Figure 2. E-Series Model EP2 Profile-style sensor dimension reference (Shown with male 6-pin DIN and D60 integral connection type option)

Standard magnet (Model EP2)

One Block magnet included with Model EP2 sensor

The *Style L 'block'* magnet (part no.: 252887) mounts on the moving machine part and travels just above the sensor's extrusion. The magnet can be mounted using ferrous metal screws on a mounting plate (customer supplied) or flat surface of the machine's moving part. The mounting plate or machine part can not extend beyond 11 mm (0.43 in.) from the top of the magnet, unless it is made of non-ferrous material. The magnet should be installed in a perpendicular orientation relative to the top surface of the sensor extrusion (see 'Figure 2'). Optimal performance is achieved when this orientation remains consistent throughout the full measurement stroke range.

BLOCK MAGNET, STYLE L (One Magnet included with each Model EP2 sensor)

(Drawing dimensions are for reference only)

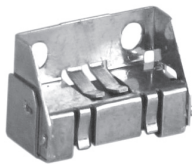
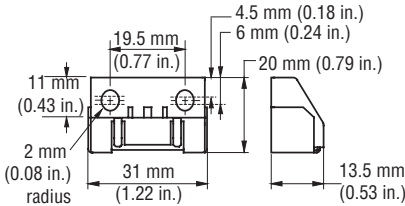
Magnet	Mounted magnet dimensions	Description	Part number
		Block magnet, Style L For Model EP2 profile-style sensor	252887

Sensor mounting

MODEL EP2 SENSOR MOUNTING

Temposonics model EP2 profile-style sensors are mounted onto a flat straight surface of the machine with moveable mounting feet. A pair (2) mounting feet are provided with each sensor. Two additional mounting feet (part no. 400802) are included for measurement stroke lengths greater than 48 inches. Mounting feet slide into side grooves and should be evenly distributed along the sensor extrusion to best secure the sensor for each particular application.

Notes:
<ol style="list-style-type: none"> 1. Additional mounting feet can be ordered separately. 2. MTS recommends using 10-32 cap screws (customer supplied) at a maximum torque of 44 in. lbs. when fastening mounting feet.

Profile-Style sensor mounting and installation reference

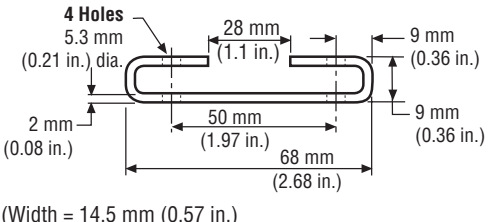
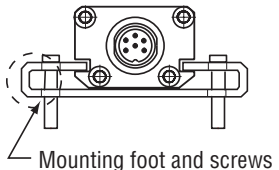
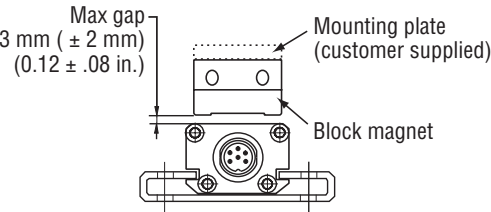
Profile-Style sensor mounting and installation reference	Mounting method	Part number
	Mounting feet, standard (304 SS) Profile-style sensor mounting for sensor model EP2	400802
	Mounting feet and screws Profile-style sensor foot installation Secure mounting feet with customer supplied 10-32 Cap screws. (recommended)	<i>Mounting feet, part number 400802</i>
	Block magnet, Style L mounting Magnet installs on a mounting plate (customer supplied) or flat surface of the machine's moving part.	<i>Block magnet, style L part number 252887</i>
		

Model EP2 connections and wiring

SENSOR INTEGRAL CONNECTOR (D60 MALE) PINOUT/
WIRE COLOR CODE (FOR EXTENSION CABLE OPTION)

The E-Series Model EP2 sensor connects directly to a controller, or interface module via male, 6-pin integral connector and extension cable option.

Wiring color and signal functions for the extension cable option are described in 'Table 1'.



Integral D6 connector (male) as viewed from the end of the sensor

Pin no.	Wire color	Signal/Function Digital-pulse outputs
1	Gray	(-) Stop
2	Pink	(+) Stop
3	Yellow	(+) Start
4	Green	(-) Start
5	Red or Brown	+24 Vdc (-15% / +20%)
6	White	DC Ground (0 Vdc)

Table 1. EP2 digital-pulse (start/stop) sensor extension cable wiring diagram

Attention:

The EP2 sensor's aluminum housing has an anodic coating which prevents the sensor's mounting feet (part no. 400802) from providing the appropriate grounding. A grounding lug (see 'Figure 3') is provided near the connector end of the sensor for a convenient connection to earth ground.

The appropriate grounding of the cable shield is required at the controller end.

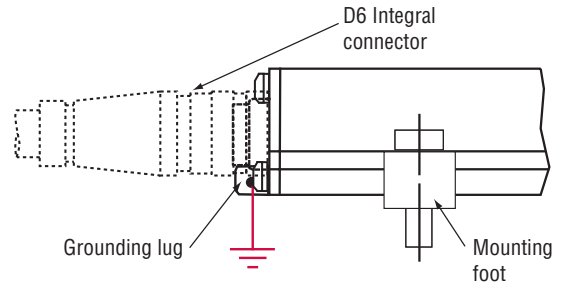

Figure 3. EP2 Sensor grounding lug location

CABLE CONNECTOR OPTIONS (FIELD INSTALLABLE) 6-PIN DIN (D60) FEMALE

(Drawing dimensions are for reference only)

Connector	Connector dimensions	Description	Part number
		Female Cable Connector, Straight Exit (Field installable) 6-Pin DIN (D60) Mates with standard male (M16) integral connector	560700
		Female Cable Connector, 90° Exit (Field installable) 6-Pin DIN (D60) Mates with standard male (M16) integral connector	560778

EXTENSION CABLE WITH CONNECTORS FOR D6 (D60) CONNECTION TYPES

Extension Cable and Connector	Description	Connection Type
	Female Connector, Straight Exit with Standard PVC Jacket Cable (Assembly Includes D6 Connector, Part No.: 560700 and Cable, Part No.:530026)	D6
	Female Connector, 90° Exit with Standard PVC Jacket Cable (Assembly Includes D6 Connector, Part No.: 560778 and Cable, Part No.:530026)	DA
	Female Connector, Straight Exit with Black Polyurethane Jacket Cable (for higher resistance to moisture, oil and cold temperatures) (Assembly Includes D6 Connector, Part No.: 560700 and Cable, Part No.:530045)	DJ
	Female Connector, 90° Exit with Black Polyurethane Jacket Cable (for higher resistance to moisture, oil and cold temperatures) (Assembly Includes D6 Connector, Part No.: 560778 and Cable, Part No.:530045)	DK

Ordering Information - Extension Cable with Connector for D6 (D60) Connection Types

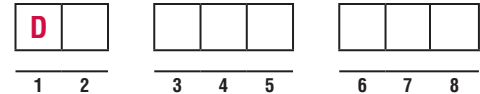

SENSOR CONNECTION TYPES _____ =

D	
---	--

1 - 2

- D6** = Female connector, straight exit (part no. 560700), and PVC jacket cable (part no. 530026)
- DA** = Female connector, 90° exit (part no. 560788), and PVC jacket cable (part no. 530026)
- DJ** = Female connector, straight exit (part no. 560700), and black polyurethane jacket cable (part no. 530045)
- DK** = Female connector, 90° exit (part no. 560788), and black polyurethane jacket cable (part no. 530045)

CABLE LENGTHS _____ =

--	--	--

3 - 5

- For standard length cables up to 100 ft**
- 005** = 5 ft.
 - 015** = 15 ft.
 - 025** = 25 ft.
 - 050** = 50 ft.
 - 100** = 100 ft.

For custom length cables over 100 ft.
 _____ = Cable length (maximum cable length is dependent on the output selected; consult MTS Applications Engineering)

CABLE TERMINATION _____ =

--	--	--

6 - 8

- P0** = Pigtail cable without connector (2 digit code)
- D6M** = D6 male connector (straight exit). Only available with the D6 option above.
- D6F** = D6 female connector (straight exit). Only available with the D6 option above.
- DAF** = D6 female connector (90° exit). Only available with the DA option above.

PRODUCT DATA SHEET

**E-Series Model EP2 Sensor, Digital-pulse (Start/Stop) Output
Ordering Information**

Use the order matrix below to configure your Model EP2 digital-pulse (start/stop) sensor order number. Contact the factory for custom sensor orders.

For your convenience, the E-Series Model EP2 sensor with digital-pulse (start/stop) output can be purchased from the MTS *Online Store* at: <http://www.mtssensorsstore.com>

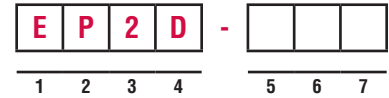

SENSOR MODEL _____ =

E	P	2	D
---	---	---	---

1 - 4

E-Series model EP2 sensor with digital-pulse (start/stop) output

____ = **MEASURING STROKE LENGTH IN INCHES** _____ =

--	--	--

5 - 7

(Contact factory for custom stroke lengths)

- | | |
|--|---|
| <p>004 = 4 inch stroke length</p> <p>006 = 6 inch stroke length</p> <p>009 = 9 inch stroke length</p> <p>012 = 12 inch stroke length</p> <p>015 = 15 inch stroke length</p> <p>018 = 18 inch stroke length</p> <p>021 = 21 inch stroke length</p> | <p>024 = 24 inch stroke length</p> <p>030 = 30 inch stroke length</p> <p>036 = 36 inch stroke length</p> <p>042 = 42 inch stroke length</p> <p>048 = 48 inch stroke length</p> <p>054 = 54 inch stroke length</p> <p>060 = 60 inch stroke length</p> |
|--|---|



Document Part Number: 551064, Revision C 01-10

MTS and Temposonics are registered trademarks of MTS Systems Corporation.
All other trademarks are the property of their respective owners.
All Temposonics sensors are covered by US patent number 5,545,984. Additional patents are pending.
Printed in USA. Copyright © 2010 MTS Systems Corporation. All Rights Reserved in all media.



**MTS Systems Corporation
Sensors Division**

3001 Sheldon Drive
Cary, North Carolina
27513, USA
Tel.: +1-800-633-7609
Fax: +1-919-677-2343
+1-800-498-4442
e-mail: sensorsinfo@mts.com
<http://www.mtssensors.com>

**MTS Sensor Technologie
GmbH & Co. KG**

Auf dem Schüffel 9
D - 58513 Lüdenscheid, Germany
Tel.: +49-2351-9587-0
Fax: +49-2351-56491
e-mail: info@mtssensor.de
<http://www.mtssensor.de>

**MTS Sensors Technology
Corporation**

737 Aihara-cho, Machida-shi
Tokyo 194-0211, Japan
Tel.: +81-42-775-3838
Fax: +81-42-775-5516
e-mail: info@mtssensor.co.jp
<http://www.mtssensor.co.jp>