

Temposonics®

Magnetostrictive Linear Position Sensors

R-Series Profinet IO RT Operation Manual



Table of contents

1. Introduction	3
1.1 Purpose and use of this manual	3
1.2 Used symbols and warnings	3
2. Safety instructions	3
2.1 Intended use	3
2.2 Forseeable misuse	3
2.3 Installation, commissioning and operation	4
2.4 Safety instructions for use in explosion-hazardous areas	4
2.5 Warranty	4
2.6 Return	4
3. Identification	5
3.1 Order code of Temposonics® RP	5
3.2 Order code of Temposonics® RH	6
3.3 Order code of Temposonics® RD4	7
3.4 Order code of Temposonics® RF	8
3.5 Nameplate	9
3.6 Approvals	9
3.7 Scope of delivery	9
4. Product description and commissioning	10
4.1 Functionality and system design	10
4.2 Styles and installation of Temposonics® RP	11
4.3 Styles and installation of Temposonics® RH	12
4.4 Styles and installation of Temposonics® RD4	15
4.4.1 Installation of RD4 with threaded flange	17
4.4.2 Installation of RD4 with pressure fit flange	18
4.4.3 Installation of RD4's sensor electronics housing	18
4.5 Styles and installation of Temposonics® RF	20
4.6 Magnet installation	23
4.7 Replacement of sensor	26
4.8 Electrical connections	27
4.9 Frequently ordered accessories	28
5. Operation	31
5.1 Getting started	31
6. Programming and configuration	31
6.1 Configuration of the network interface	31
6.2 Configuration of the sensor designation	32
6.3 Controller setting and preparation of the network	33
6.4 Integration of GSDML files (of the sensor)	35
6.5 Integration and configuration of the sensors with MTS profile	35
6.6 Integration and configuration of the sensors with encoder profile	38
6.7 Error diagnosis	43
7. Maintenance and troubleshooting	44
7.1 Error conditions, troubleshooting	44
7.2 Maintenance	44
7.3 Repair	44
7.4 List of spare parts	44
7.5 Transport and storage	44
8. Removal from service / dismantling	44
9. Technical data	45
9.1 Technical data Temposonics® RP	45
9.2 Technical data Temposonics® RH	46
9.3 Technical data Temposonics® RD4	47
9.4 Technical data Temposonics® RF	48
10. Appendix	49

1. Introduction

1.1 Purpose and use of this manual

Before starting the operation of Temposonics® position sensors, read this documentation thoroughly and follow the safety information. Keep the manual for future reference!

The content of this technical documentation and of its appendix is intended to provide information on mounting, installation and commissioning by qualified automation personnel ¹ or instructed service technicians who are familiar with the project planning and dealing with Temposonics® sensors.

1.2 Used symbols and warnings

Warnings are intended for your personal safety and for avoidance of damage to the described product or connected devices. In this documentation, safety information and warnings to avoid danger that might affect the life and health of operating or service personnel or cause material damage are highlighted by the preceding pictogram which is defined below.

Symbol	Meaning
NOTICE	This symbol is used to point to situations that may lead to material damage, but not to personal injury.

2. Safety instructions

2.1 Intended use

This product may be used only for the applications defined under item 1 and only in conjunction with the third-party devices and components recommended or approved by MTS Sensors. As a prerequisite of proper and safe operation the product requires correct transport, storage, mounting and commissioning and must be operated with utmost care.

- The sensor systems of all Temposonics® series are intended exclusively for measurement tasks encountered in industrial, commercial and laboratory applications. The sensors are considered as system accessories and must be connected to suitable evaluation electronics, e.g. a PLC, IPC, indicator or other electronic control unit.

^{1/} The term qualified technical personnel characterizes persons who:

- are familiar with the safety concepts of automation technology applicable to the particular project
- are competent in the field of electromagnetic compatibility (EMC)
- have received adequate training for commissioning and service operations
- are familiar with the operation of the device and know the information required for correct operation provided in the product documentation

2.2 Forseeable misuse

Forseeable misuse	Consequence
Wrong sensor connection	The sensor will not work properly or will be destroyed
Operate the sensor out of the operating temperature range	No signal output The sensor can be damaged
Power supply is out of the defined range	Signal output is wrong / no signal output / the sensor will be damaged
Position measurement is influenced by an external magnetic field	Signal output is wrong
Cables are damaged	Short circuit – the sensor can be destroyed / sensor does not respond
Spacers are missing / are installed in a wrong order	Error in position measurement
Wrong connection of ground / shield	Signal output is disturbed The electronics can be damaged
Use of a magnet that is not certified by MTS Sensors	Error in position measurement

Do not reprocess the sensor afterwards.
→ The sensor might be damaged.

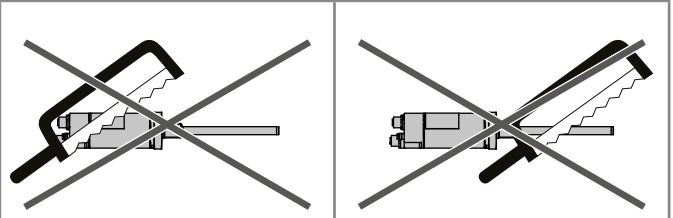

Do not step on the sensor.
→ The sensor might be damaged.

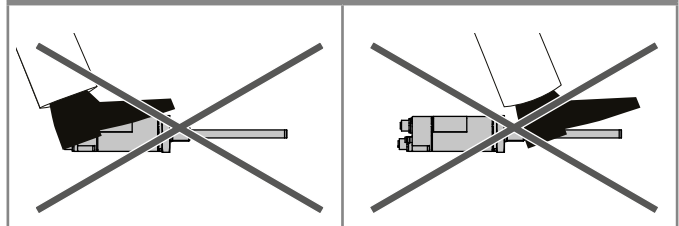

2.3 Installation, commissioning and operation

The position sensors must be used only in technically safe condition. To maintain this condition and to ensure safe operation, installation, connection and service, work may be performed only by qualified technical personnel.

If danger of injury to persons or of damage to operating equipment is caused by sensor failure or malfunction, additional safety measures such as plausibility checks, limit switches, EMERGENCY STOP systems, protective devices etc. are required. In the event of trouble, shut down the sensor and protect it against accidental operation.

Safety instructions for commissioning

To maintain the sensor's operability, it is mandatory to follow the instructions given below.

1. Protect the sensor against mechanical damage during installation and operation.
2. Do not open or dismantle the sensor.
3. Connect the sensor very carefully and pay attention to the polarity of connections and power supply.
4. Use only approved power supplies.
5. It is indispensable to ensure that the specified permissible limit values of the sensor for operating voltage, environmental conditions, etc. are met.
6. Check the function of the sensor regularly and provide documentation of the checks.
7. Before applying power, ensure that nobody's safety is jeopardized by starting machines.

2.4 Safety instructions for use in explosion-hazardous areas

The sensor is not suitable for operation in explosion-hazardous areas.

2.5 Warranty

MTS Sensors grants a warranty period for the Temposonics® position sensors and supplied accessories relating to material defects and faults that occur despite correct use in accordance with the intended application². The MTS Sensors obligation is limited to repair or replacement of any defective part of the unit. No warranty can be provided for defects that are due to improper use or above average stress of the product, as well as for wear parts. Under no circumstances will MTS Sensors accept liability in the event of offense against the warranty rules, no matter if these have been assured or expected, even in case of fault or negligence of the company. MTS Sensors explicitly excludes any further warranties. Neither the company's representatives, agents, dealers nor employees are authorized to increase or change the scope of warranty.

2.6 Return

For diagnostic purposes, the sensor can be returned to MTS Sensors. Any shipment cost is the responsibility of the sender². For a corresponding form, see chapter "10. Appendix" on page 49.

^{2/} See also applicable MTS Sensors terms of sales and delivery on: www.mtssensors.com

3. Identification

3.1 Order code of Temposonics® RP

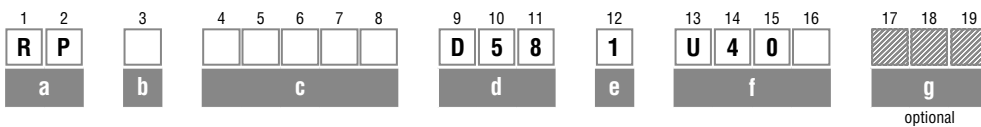

a	Sensor model
R P	Profile

b	Design
G	Magnet slider, joint on top, backlash free (part no. 253 421)
M	U-magnet, OD33 (part no. 251 416-2)
S	Magnet slider, joint on top (part no. 252 182)
V	Magnet slider, joint at front (part no. 252 184)

c	Stroke length
X X X X M	0025...5080 mm
Standard stroke length (mm)*	
	25 ... 500 mm
	500 ... 2500 mm
	2500 ... 5080 mm
	Ordering steps
	25 mm
	50 mm
	100 mm
X X X X U	001.0...200.0 in.
Standard stroke length (in.)*	
	1 ... 20 in.
	20 ... 100 in.
	100 ... 200 in.
	Ordering steps
	1 in.
	2 in.
	4 in.

d	Connection type
D 5 8	2 × M12 female connectors (5 pin), 1 × M12 male connector (4 pin)

e	Operating voltage
1	+24 VDC (–15 / +20 %)

f	Output
U 4 0 1	Profinet IO RT, Encoder Profile, 1 magnet
U 4 0 2	Profinet IO RT, MTS Profile, 1...19 magnets

Optional:

g	Magnet number for multi-position measurement ³
Z X X	Z02...Z19 (2...19 positions)

*/ Non standard stroke lengths are available; must be encoded in 5 mm / 0.1 in. increments

3/ Note: Specify magnet number for your sensing application and order separately

3.2 Order code of Temposonics® RH

1	2	3	4	5	6	7	8	9	10	11	12	13	14	15	16	17	18	19
R	H							D	5	8	1	U	4	0				
a		b	c					d			e	f				g		

optional

a	Sensor model	
R	H	Rod

b	Design
B	Base unit ⁴
D	Threaded flange M18×1.5-6g (bushing on rod end)
H	Threaded flange ¾"-16 UNF-3A (with fluoroelastomer housing-seal)
J	Threaded flange M22×1.5-6g (rod Ø 12.7 mm, 800 bar)
M	Threaded flange M18×1.5-6g (standard)
R	Threaded flange M18×1.5-6g (thread M4 at rod end)
S	Threaded flange ¾"-16 UNF-3A (standard)
T	Threaded flange ¾"-16 UNF-3A (with raised-face)
U	Threaded flange ¾"-16 UNF-3A (with raised-face & fluoroelastomer housing-seal)
V	Threaded flange M18×1.5-6g (with fluoroelastomer housing-seal)

c	Stroke length				
X	X	X	X	M	0025...7620 mm
Standard stroke length (mm)** Ordering steps					
		25 ... 500 mm		5 mm	
		500 ... 750 mm		10 mm	
		750...1000 mm		25 mm	
		1000...2500 mm		50 mm	
		2500...5000 mm		100 mm	
		5000...7620 mm		250 mm	
X	X	X	X	U	001.0...300.0 in.
Standard stroke length (in.)** Ordering steps					
		1 ... 20 in.		0.2 in.	
		20 ... 30 in.		0.4 in.	
		30 ... 40 in.		1.0 in.	
		40...100 in.		2.0 in.	
		100...200 in.		4.0 in.	
		200...300 in.		10.0 in.	

d	Connection type		
D	5	8	2 × M12 female connectors (5 pin), 1 × M12 male connector (4 pin)

e	Operating voltage	
1	+24 VDC (-15 / +20 %)	

f	Output			
U	4	0	1	Profinet IO RT, Encoder Profile, 1 magnet
U	4	0	2	Profinet IO RT, MTS Profile, 1...19 magnets

Optional:

g	Magnet number for multi-position measurement ⁵		
Z	X	X	Z02...Z19 (2...19 positions)

4/ RH-B is for replacement (see chapter 4.7)

5/ Note: Specify magnet number for your sensing application and order separately

*/ Non standard stroke lengths are available; must be encoded in 5 mm / 0.1 in. increments

3.3 Order code of Temposonics® RD4

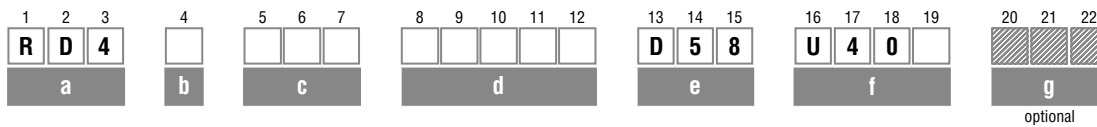

a	Sensor model
R D 4	Detached sensor electronics

b	Design
C	Threaded flange M18×1.5-6g, A/F 46
D	Threaded flange ¾"-16 UNF-3A, A/F 46
G	Threaded flange M18×1.5-6g, A/F 24
M	Threaded flange M18×1.5-6g, A/F 23
S	Pressure fit flange Ø 26.9 mm f6
T	Threaded flange ¾"-16 UNF-3A, A/F 23

c	Integral cable of sensor rod
For side cable entry on sensor electronics housing	
D 1 S	PUR cable with M16 connector, length 250 mm (9.8 in.)
D 2 S	PUR cable with M16 connector, length 400 mm (15.7 in.)
D 3 S	PUR cable with M16 connector, length 600 mm (23.6 in.)
For bottom cable entry on sensor electronics housing	
R 2 B	PUR cable / wires with flat connector, length 65 mm (2.6 in.)
R 4 B	PUR cable / wires with flat connector, length 170 mm (6.7 in.)
R 5 B	PUR cable / wires with flat connector length 230 mm (9.1 in.)
R 6 B	PUR cable / wires with flat connector, length 350 mm (13.8 in.)

d	Stroke length
X X X X M	Flange »C«, »D«, »G«, »M«, »T«: 0025...5080 mm Flange »S«: 0025...2540 mm

Standard stroke length (mm)*	Ordering steps
25 ... 500 mm	5 mm
500 ... 750 mm	10 mm
750...1000 mm	25 mm
1000...2500 mm	50 mm
2500...5080 mm	100 mm

X X X X U	Flange »C«, »D«, »G«, »M«, »T«: 001.0...200.0 in. Flange »S«: 001.0...100.0 in.
-----------	--

Standard stroke length (in.)*	Ordering steps
1 ... 20 in.	0.2 in.
20 ... 30 in.	0.4 in.
30 ... 40 in.	1.0 in.
40...100 in.	2.0 in.
100...200 in.	4.0 in.

e	Connection type
D 5 8	2 × M12 female connectors (5 pin), 1 × M12 male connector (4 pin)

Operating voltage
+24 VDC (-15 / +20 %); Standard, not indicated in order code

f	Output
U 4 0 1	Profinet IO RT, Encoder Profile, 1 magnet
U 4 0 2	Profinet IO RT, MTS Profile, 1...19 magnets

Optional:

g	Magnet number for multi-position measurement ⁶
Z X X	Z02...Z19 (2...19 positions)

*/ Non standard stroke lengths are available; must be encoded in 5 mm / 0.1 in. increments

6/ Note: Specify magnet number for your sensing application and order separately

3.4 Order code of Temposonics® RF

1	2	3	4	5	6	7	8	9	10	11	12	13	14	15	16	17	18	19	20
R	F								D	5	8	1	U	4	0				
a		b	c						d			e	f				g		

optional

a	Sensor model
R F	Flexible sensor rod

b	Design
C	Base unit
M	Threaded flange M18×1.5-6g
S	Threaded flange ¾"-16 UNF-3A

c	Stroke length
X X X X X M	00150...20,000 mm
Standard stroke length (mm)* Ordering steps	
150 ... 1000 mm	50 mm
1000 ... 5000 mm	100 mm
5000 ... 10,000 mm	250 mm
10,000...15,000 mm	500 mm
15,000...20,000 mm	1000 mm
X X X X X U	0006.0...0787.0 in.
Standard stroke length (in.)* Ordering steps	
6 ... 40 in.	2 in.
40...197 in.	4 in.
197...394 in.	10 in.
394...591 in.	20 in.
591...787 in.	40 in.

d	Connection type
D 5 8	2 × M12 female connectors (5 pin), 1 × M12 male connector (4 pin)

e	Operating voltage
1	+24 VDC (-15 / +20 %)

f	Output
U 4 0 1	Profinet IO RT, Encoder Profile, 1 magnet
U 4 0 2	Profinet IO RT, MTS Profile, 1...19 magnets

Optional:

g	Magnet number for multi-position measurement ⁷
Z X X	Z02...Z19 (2...19 positions)

*/ Non standard stroke lengths are available; must be encoded in 5 mm / 0.1 in. increments

^{7/} Note: Specify magnet number for your sensing application and order separately

3.5 Nameplate

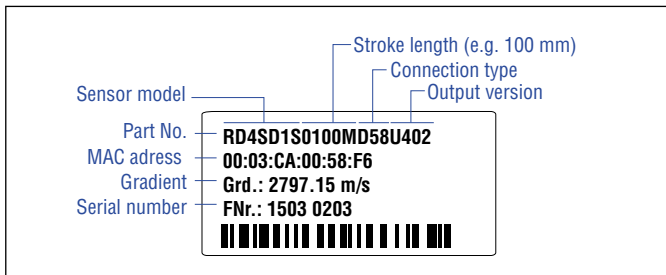

Fig. 1: Example of nameplate of a R-Series RD4 sensor

3.6 Approvals

- CE certified (RP / RH / RF)
- UL/cUL certified (RP / RH)
- EAC certified
- PNO certified

3.7 Scope of delivery

RP (profile sensor):

- Sensor
- Position magnet
- 2 mounting clamps up to 1250 mm (50 in.) stroke length +
1 mounting clamp for each 500 mm (20 in.) additional stroke length

RH (rod sensor):

- RH-B: Base unit, 2 socket screws M4
- RH-D / -H / -J / -M / -R / -S / -T / -U / -V: Sensor, O-ring

RD4 (detached sensor electronics):

- RD4-C / -D / -G / -M / -T: Sensor, O-ring
- RD4-S: Sensor, O-ring, back-up ring

RF (flexible sensor rod):

- RF-C: Base unit
- RF-M / -S: Sensor, O-ring

4. Product description and commissioning

4.1 Functionality and system design

Product designation

- Position sensor Temposonics® R-Series

Sensor model

- Temposonics® RP (profile sensor)
- Temposonics® RH (rod sensor)
- Temposonics® RD4 (detached sensor electronics)
- Temposonics® RF (flexible sensor rod)

Stroke length

- RP 25... 5080 mm (1...200 in.)
- RH 25... 7620 mm (1...300 in.)
- RD4 25... 5080 mm (1...200 in.)
- RF 150...20000 mm (6...787 in.)

Output signal

- Profinet IO RT

Application

The Temposonics® position sensors are used for measurement and conversion of the length (position) variable in the fields of automated systems and mechanical engineering.

Principle of operation and system construction

The absolute, linear position sensors provided by MTS Sensors rely on the company's proprietary Temposonics® magnetostrictive technology, which can determine position with a high level of precision and robustness. Each Temposonics® position sensor consists of a ferromagnetic waveguide, a position magnet, a strain pulse converter and supporting electronics. The magnet, connected to the object in motion in the application, generates a magnetic field at its location on the waveguide. A short current pulse is applied to the waveguide. This creates a momentary radial magnetic field and torsional strain on the waveguide. The momentary interaction of the magnetic fields releases a torsional strain pulse that propagates the length of the waveguide. When the ultrasonic wave reaches the end of the waveguide it is converted into an electrical signal. Since the speed of the ultrasonic wave in the waveguide is precisely known, the time required to receive the return signal can be converted into a linear position measurement with both high accuracy and repeatability.

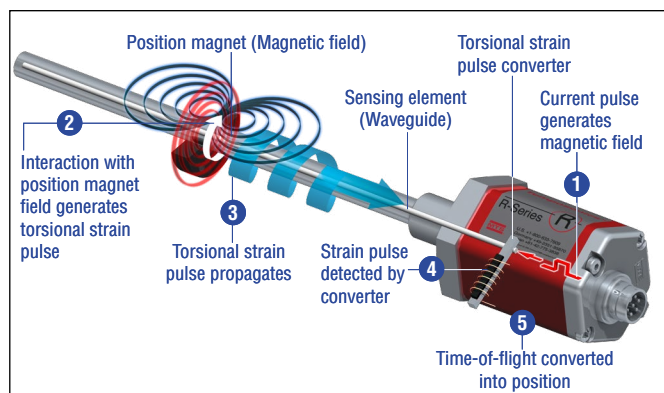

Fig. 2: Time-based magnetostrictive position sensing principle

Modular mechanical and electronic construction

- The sensor rod or profile protects the inner sensor element.
- The sensor electronics housing, a rugged aluminum construction, contains the complete electronic interface with active signal conditioning. Double shielding ensures high safety of operation and optimum EMC (Electromagnetic Compatibility).
- The external position magnet is a permanent magnet. Mounted on the mobile machine part, it travels along the sensor rod or profile and triggers the measurement through the sensor rod wall.
- The sensor can be connected directly to a control system. Its electronics generates a strictly position-proportional signal output between start and end position.

4.2 Styles and installation of Temposonics® RP

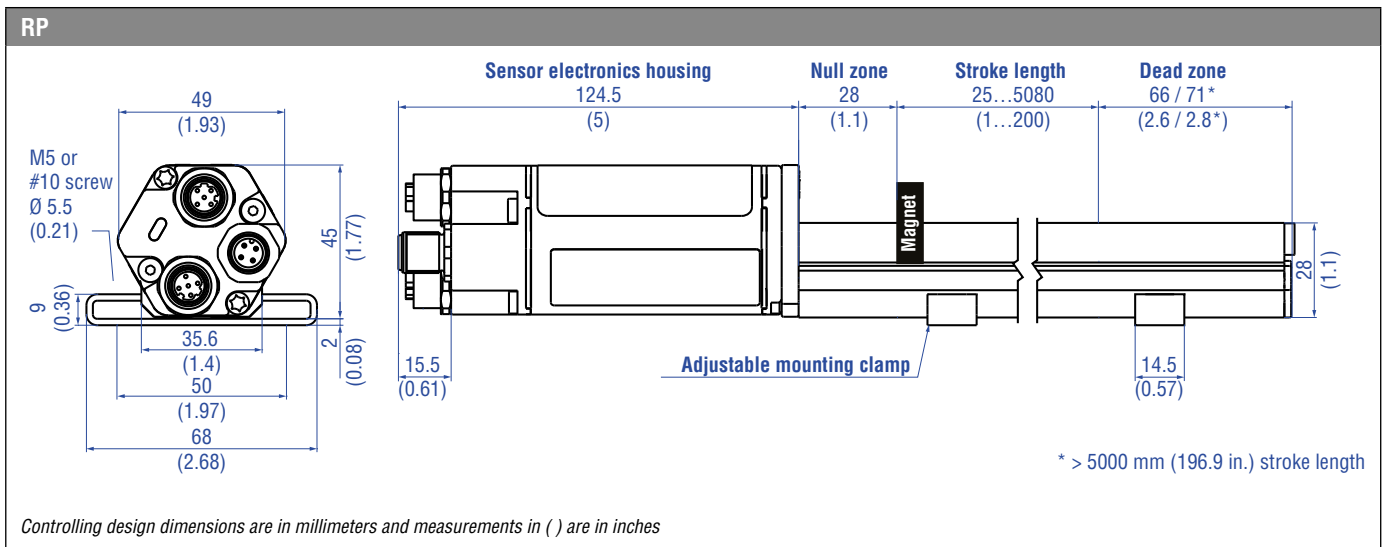

Fig. 3: Temposonics® RP with U-magnet

Installation of RP

The position sensor can be installed in any position. Normally, the sensor is firmly installed and the position magnet is fastened to the mobile machine part. Thus it can travel along the sensor profile. The sensor is fitted on a flat machine surface using the mounting clamps (Fig. 4). A length-dependent number of these clamps are delivered with the sensor and must be distributed over the profile at regular distances. For fastening use M5×20 screws to DIN 6912 that should be tightened with a fastening torque of 5 Nm.

NOTICE

Take care to mount the sensor in an axially parallel position to avoid damage to magnet and sensor.

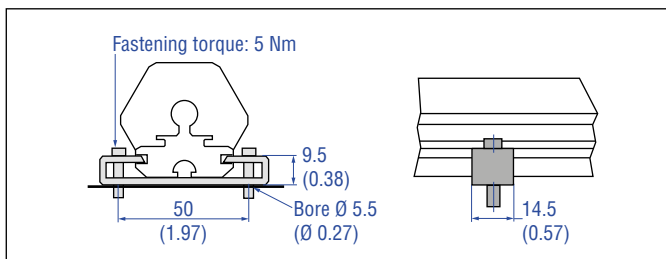

Fig. 4: Mounting clamps (part no. 400 802) with cylinder screw M5×20

Alternative:

If only limited space is available, the profile sensor can be mounted also via the T-rail in the profile bottom using an T-slot nut M5 (part no. 401 602) or a sliding block (Fig. 5).

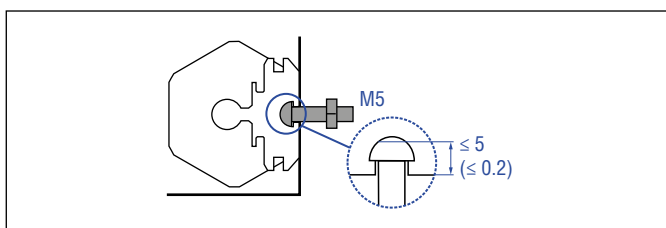

Fig. 5: T-slot nut M5 (part no. 401 602)

Controlling design dimensions are in millimeters and measurements in () are in inches

4.3 Styles and installation of Temposonics® RH

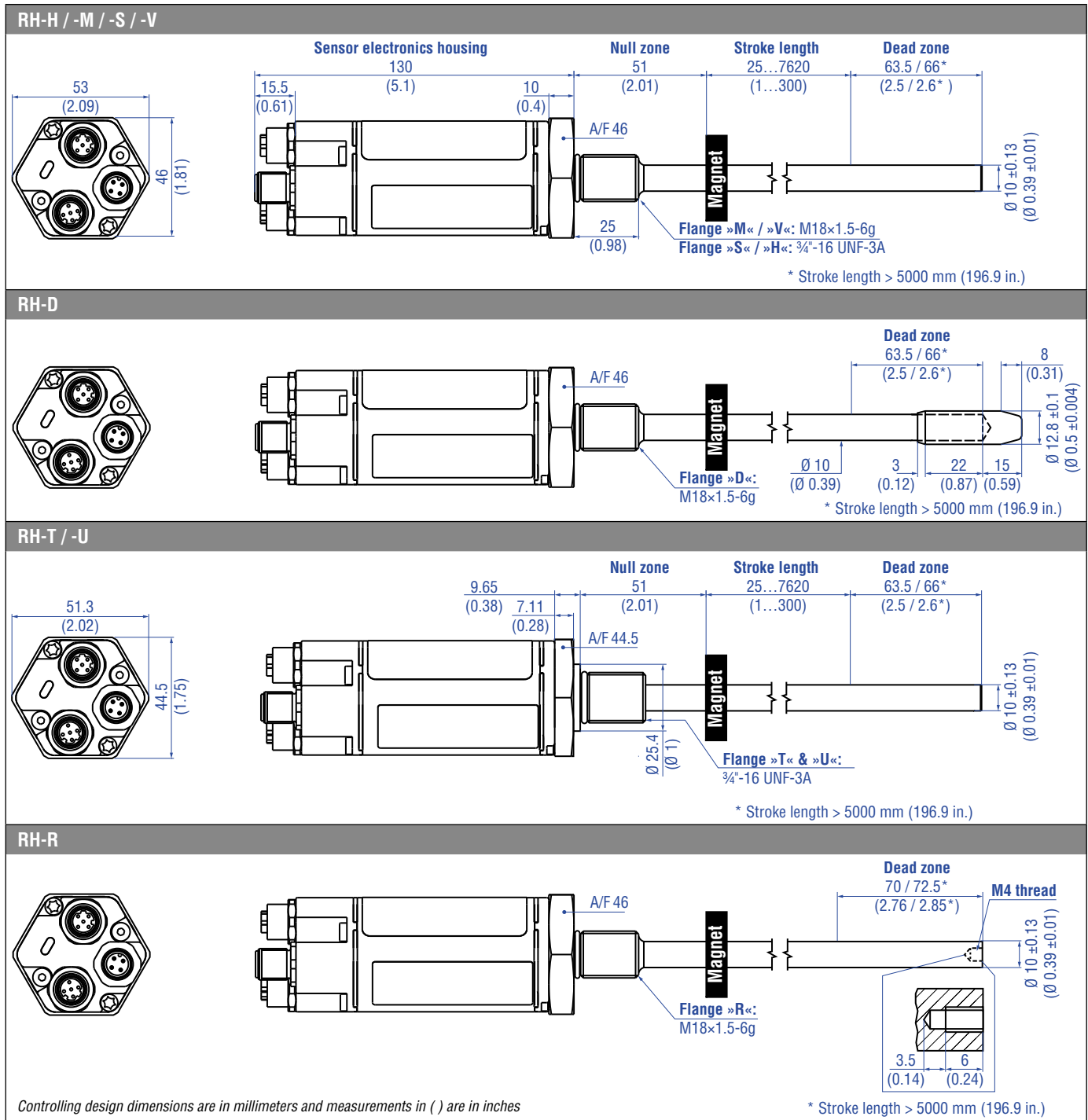

Fig. 6: Temposonics® RH with ring magnet part 1

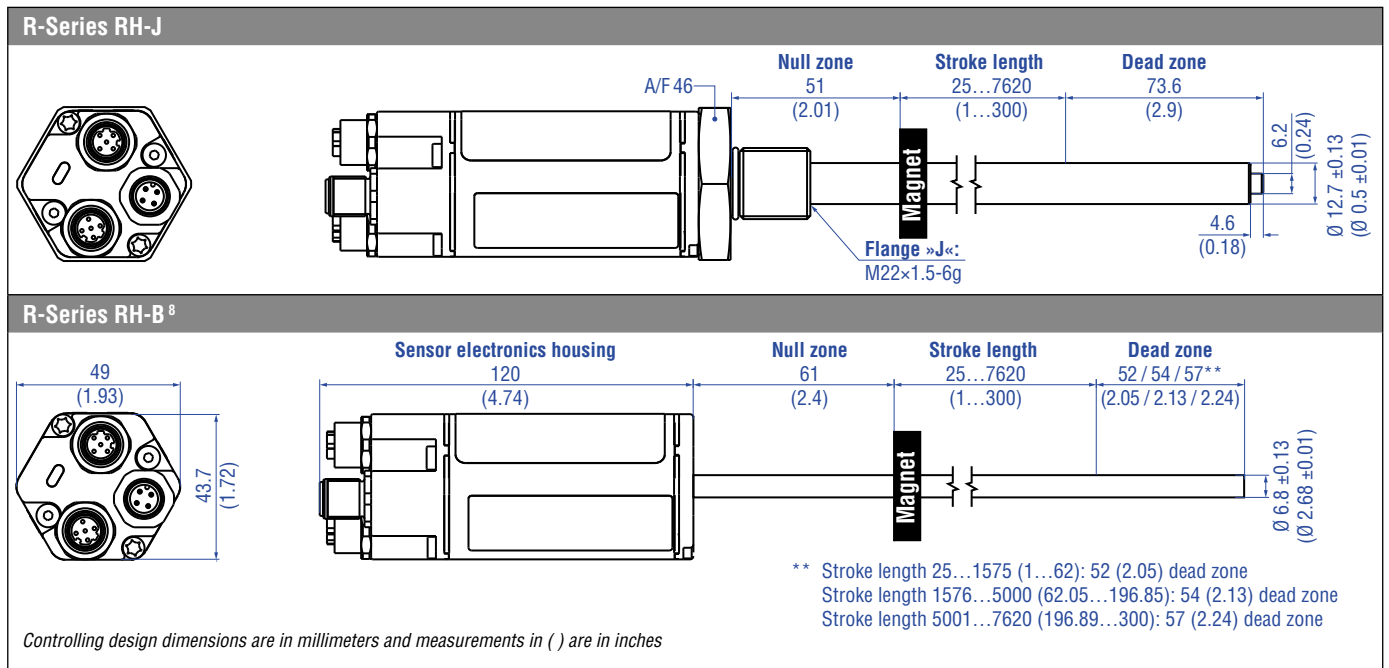

Fig. 7: Temposonics® RH with ring magnet part 2

Installation of RH with threaded flange »D«, »H«, »J«, »M«, »R«, »S«, »T«, »U« & »V«

Fix the sensor rod via threaded flange M18×1.5-6g, M22×1.5-6g or ¾"-16 UNF-3A.

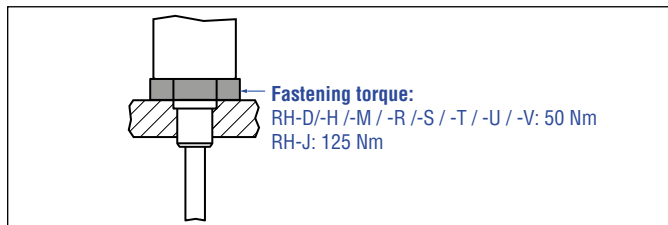

Fig. 8: Mounting example of threaded flange »D«, »H«, »J«, »M«, »R«, »S«, »T«, »U« & »V«

Installation of a rod-style sensor in a fluid cylinder

The rod-style version has been developed for direct stroke measurement in a fluid cylinder. Mount the sensor via threaded flange or a hex nut.

- Mounted on the face of the piston, the position magnet travels over the rod without touching it and indicates the exact position through the rod wall – independent of the hydraulic fluid.
- The pressure resistant sensor rod is installed into a bore in the piston rod.
- The base unit is mounted by means of only two screws. It is the only part that needs to be replaced if servicing is required, i.e. the hydraulic circuit remains closed. For more information see chapter "4.7 Replacement of sensor" on page 26.

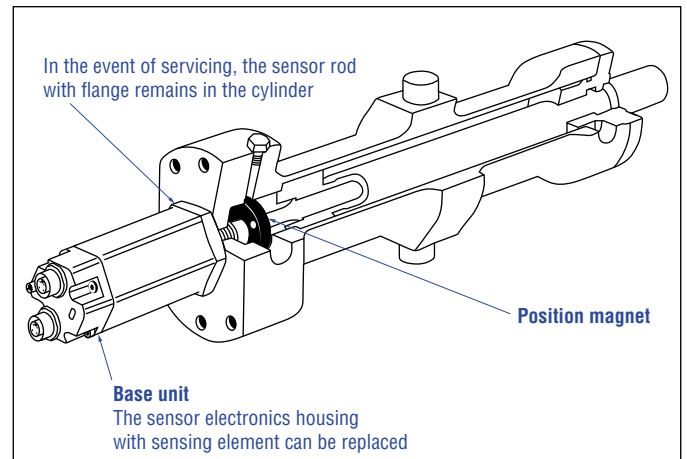

Fig. 9: Sensor in cylinder

Hydraulics sealing

There are two ways to seal the flange contact surface (Fig. 10):

1. A sealing by using an O-ring (e.g. 22.4 × 2.65 mm (0.88 × 0.1 in.), 25.07 × 2.62 mm (0.99 × 0.1 in.)) in a cylinder bottom groove.
2. A sealing by using an O-ring in the undercut.

For threaded flange (¾"-16 UNF-3A) »H« / »S« / »T« / »U«:

O-ring 16.4 × 2.2 mm (0.65 × 0.09 in.) (part no. 560 315)

For threaded flange (M18×1.5-6g) »D« / »M« / »R« / »V«:

O-ring 15.3 × 2.2 mm (0.60 × 0.09 in.) (part no. 401 133)

For threaded flange (M22×1.5-6g) »J«:

O-ring 19.2 × 2.2 mm (0.76 × 0.09 in.) (part no. 561 337)

8/ RH-B is for replacement (see chapter 4.7)

Temposonics® R-Series Profinet IO RT
 Operation Manual

In the case of threaded flange M18×1.5-6g or M22×1.5-6g, provide a screw hole based on ISO 6149-1 (Fig. 11). See ISO 6149-1 for further information.

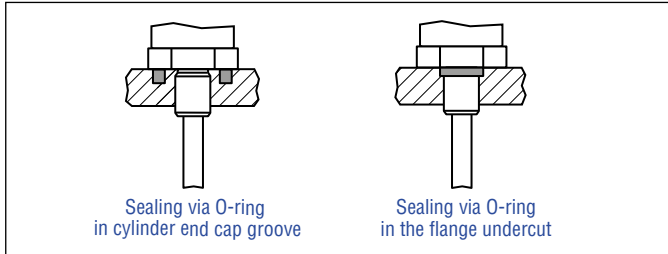

Fig. 10: Possibilities of sealing

- Note the fastening torque of:
 RH-D/-H /-M / -R /-S / -T / -U / -V: 50 Nm
 RH-J: 125 Nm
- Seat the flange contact surface completely on the cylinder mounting surface.
- The cylinder manufacturer determines the pressure-resistant gasket (copper gasket, O-ring, etc.).
- The position magnet should not grind on the sensor rod.
- The piston rod drilling
 (RH-H/-M/-R/-S/-T/-U/-V: rod \varnothing 10 mm: $\geq \varnothing$ 13 mm ($\geq \varnothing$ 0.51 in.);
 RH-D: rod \varnothing 10 mm: $\geq \varnothing$ 16 mm ($\geq \varnothing$ 0.63 in.); RH-J: rod \varnothing 12.7 mm: $\geq \varnothing$ 16 mm ($\geq \varnothing$ 0.63 in.)) depends on the pressure and piston speed.
- Adhere to the information relating to operating pressure.
- Protect the sensor rod against wear.

Notice for metric threaded flanges

Thread ($d_1 \times P$)	d_2	d_3	d_4	d_5 +0.1 0	L_1 +0.4 0	L_2	L_3	L_4	Z° $\pm 1^\circ$
RH-M / -R / -V									
M18×1.5-6g	55	≥ 13	24.5	19.8	2.4	28.5	2	26	15°
RH-D									
M18×1.5-6g	55	≥ 16	24.5	19.8	2.4	28.5	2	26	15°
RH-J									
M22×1.5-6g	55	≥ 16	27.5	23.8	2.4	28.5	2	26	15°

Controlling design dimensions are in millimeters

Fig. 11: Notice for metric threaded flange M18×1.5-6g / M22×1.5-6g based on DIN ISO 6149-1

4.4 Styles and installation of Temposonics® RD4

Sensor electronics housing with bottom cable entry

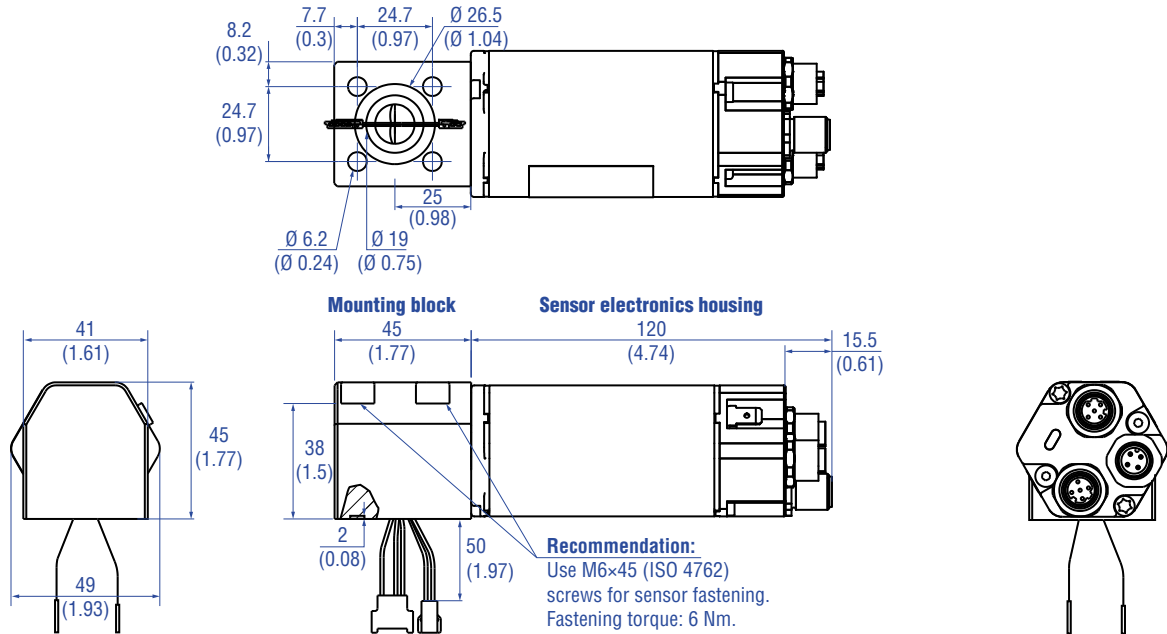

Sensor electronics housing with side cable entry

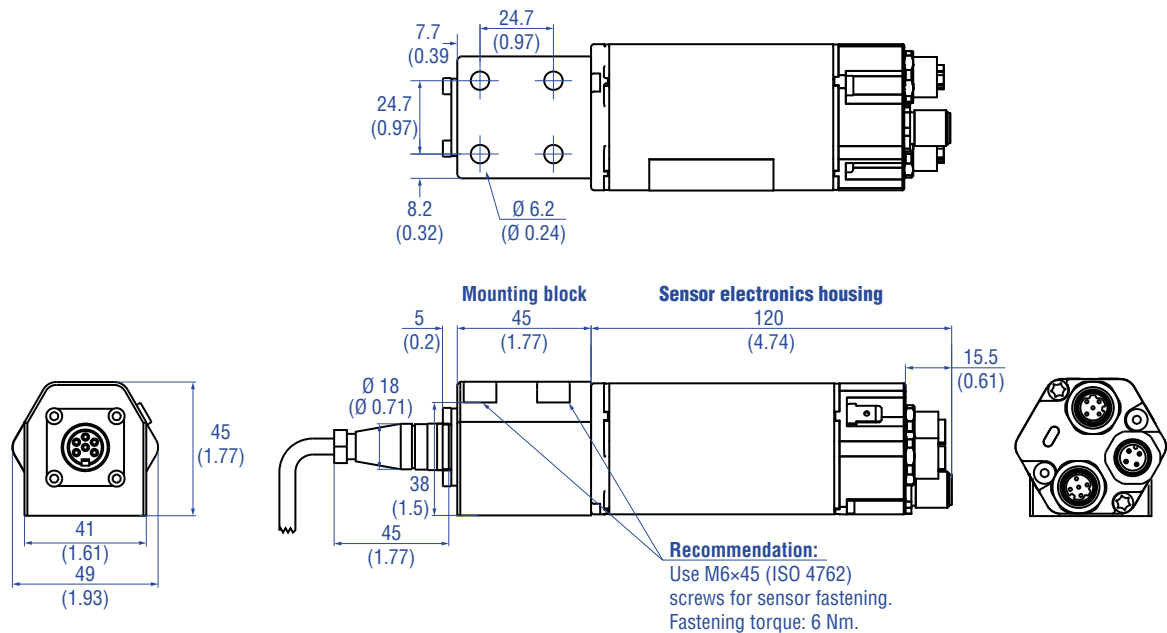

Controlling design dimensions are in millimeters and measurements in () are in inches

Fig. 12: Temposonics® RD4 sensor electronics housings

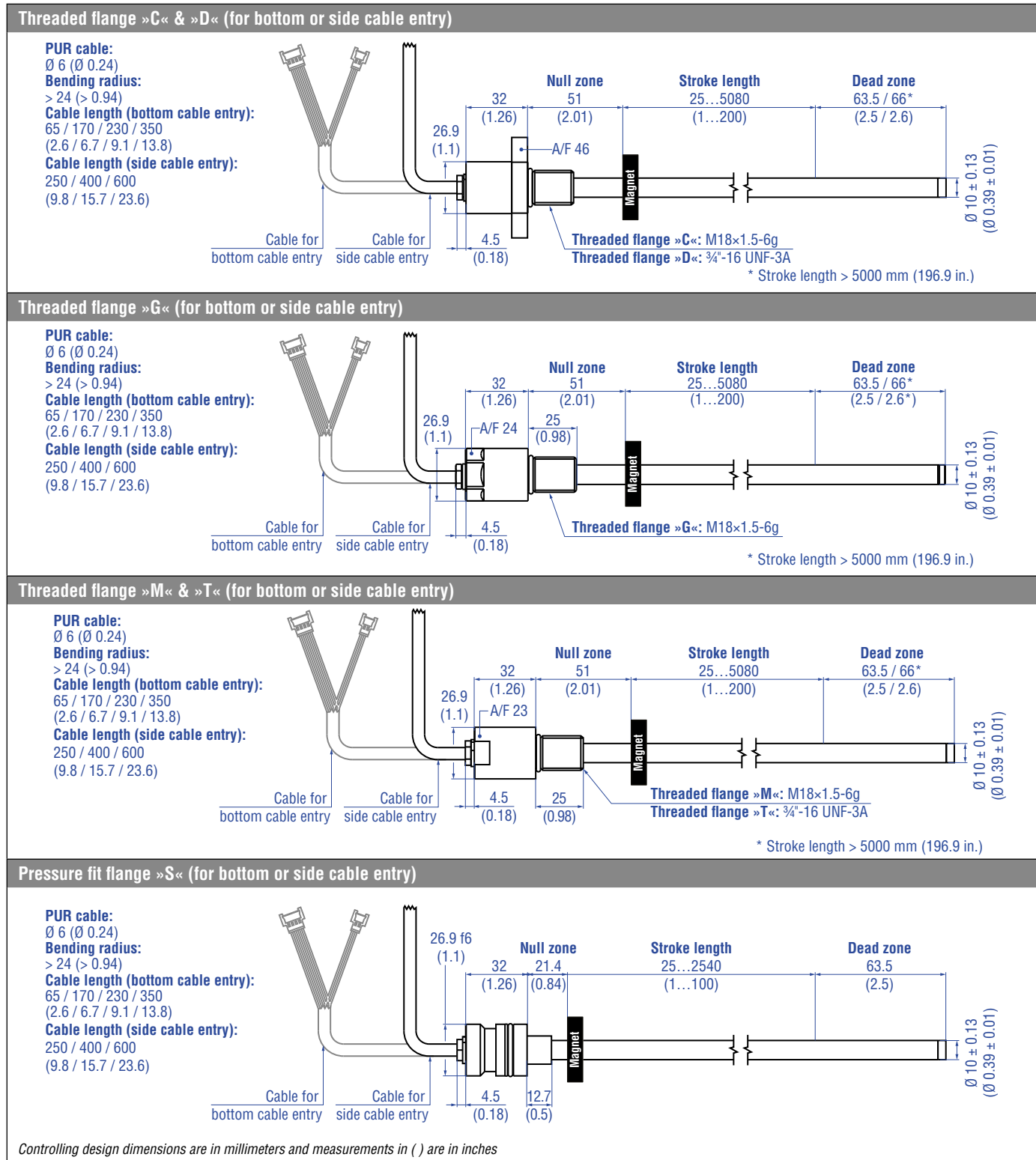

Fig. 13: Temposonics RD4 flanges with ring magnet

NOTICE

Note for installation respectively for replacement
The serial numbers (S/N:) of cable and sensor electronics housing must match so that the position measurement is correct.

Serial number example
Nr.: 1503 0203

NOTICE

Mount the sensor as follows:

1. Mount the flange with sensor rod
2. Mount the sensor electronics housing
3. Connect the cable between flange and the sensor electronics housing

The steps mentioned above will be explained in chapter 4.4.1, chapter 4.4.2 and chapter 4.4.3.

4.4.1 Installation of RD4 with threaded flange

Fix the sensor rod via threaded flange M18x1.5-6g or 3/4"-16 UNF-3A.

Fastening torque 50 Nm

Threaded flange »C« / »D« Threaded flange »M« / »T«, »G«

Fig. 14: Mounting example of threaded flange »C / D«, »M / T« & »G«

Installation of a rod-style sensor in a fluid cylinder

The rod-style version has been developed for direct stroke measurement in a fluid cylinder. Mount the sensor via threaded flange or a hex nut.

- Mounted on the face of the piston, the position magnet travels over the rod without touching it and indicates the exact position through the rod wall – independent of the hydraulic fluid.
- The pressure resistant sensor rod is installed into a bore in the piston rod.

Controlling design dimensions are in millimeters and measurements in () are in inches

Hydraulics sealing

There are the following ways to seal the flange contact surface (Fig. 15):

- For threaded flange »C« / »D«:**
1. A sealing by using an O-ring (e.g. 22.4 x 2.65 mm (0.88 x 0.1 in.) 25.07 x 2.62 mm (0.99 x 0.1 in.)) in a cylinder end cap groove.
- For threaded flange (3/4"-16 UNF-3A) »D« / »T«:**
2. A sealing by using an O-ring 16.4 x 2.2 mm (0.65 x 0.09 in.) (part no. 560315) in the undercut.
- For threaded flange (M18x1.5-6g) »C« / »M« & »G«:**
3. A sealing by using O-ring 15.3 x 2.2 mm (0.6 x 0.09 in.) (part no. 401133) in the undercut. In this case a screw hole based on ISO 6149-1 (Fig. 16) must be provided. See ISO 6149-1 for further information.

For threaded flange »C« / »D« For threaded flange »D« / »T« For threaded flange »C« / »M« & »G«

Sealing via O-ring e.g. 22.4 x 2.65 (0.88 x 0.1) in cylinder end cap groove Sealing via O-ring 16.4 x 2.2 (0.65 x 0.09) in the flange undercut Sealing via O-ring 15.3 x 2.2 (0.6 x 0.09) in the flange undercut

Fig. 15: Possibilities of sealing

- Note the fastening torque of 50 Nm.
- Seat the flange contact surface completely on the cylinder mounting surface.
- The cylinder manufacturer determines the pressure-resistant gasket (copper gasket, O-ring, etc.).
- The position magnet should not grind on the sensor rod.
- The piston rod drilling ($\geq \varnothing 13$ mm ($\geq \varnothing 0.51$ in.)) depends on the pressure and piston speed.
- Adhere to the information relating to operating pressure.
- Protect the sensor rod against wear.

Notice for metric threaded flanges

Thread (d ₁ x P)	d ₂	d ₃	d ₄	d ₅	L ₁	L ₂	L ₃	L ₄	Z°
				+0.1 0	+0.4 0				±1°
RD4-C									
M18x1.5-6g	55	≥ 13	24.5	19.8	2.4	28.5	2	26	15°
RD4-G / -M									
M18x1.5-6g	30	≥ 13	24.5	19.8	2.4	28.5	2	26	15°

Controlling design dimensions are in millimeters

This dimension applies when tap drill cannot pass through entire boss.

Fig. 16: Notice for metric threaded flange M18x1.5-6g based on DIN ISO 6149-1

4.4.2 Installation of RD4 with pressure fit flange

Cylinder mounting

Install the rod using the pressure fit flange. Seal it off by means of the O-ring and the back-up ring. Block the pressure fit flange using a shoulder screw (Fig. 18). For details of the pressure fit flange »S« see Fig. 18. Also note the mounting examples in Fig. 19 and Fig. 20.

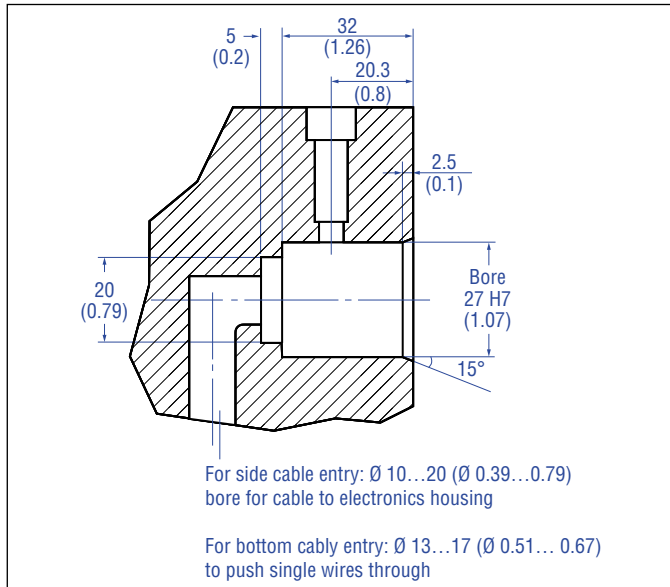

Fig. 17: Example of mounting detail: Shoulder screw 8-M6 (ISO 7379) with internal hexagon

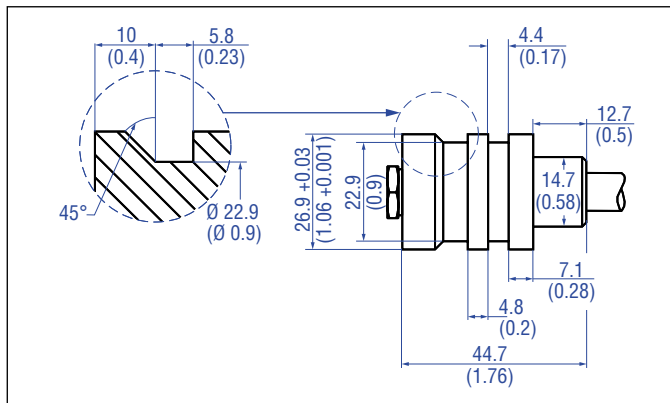

Fig. 18: Pressure fit flange »S« details

Note for cylinder installation:

- The position magnet should not grind on the sensor rod.
- The piston rod drilling ($\geq \text{Ø } 13 \text{ mm}$ ($\geq \text{Ø } 0.51 \text{ in.}$)) depends on the pressure and piston speed.
- Adhere to the information relating to operating pressure.
- Protect the sensor rod against wear.

4.4.3 Installation of RD4's sensor electronics housing

The following section explains the connection of a RD4 sensor with bottom cable entry (Fig. 19) and side cable entry (Fig. 20) based on RD4-S. The sensor electronics of RD4 sensors with threaded flange are mounted in the same way.

Sensor electronics with bottom cable entry

Connect the rod via the connector to the sensor electronics. Mount the sensor electronics so that you can lead the cables below the bottom of the housing. Thus the sensor system including the connection cables is fully encapsulated and protected against external disturbances (Fig. 19). Note the bending radius of the cable if you run the cable between sensor electronics and rod (see Fig. 13).

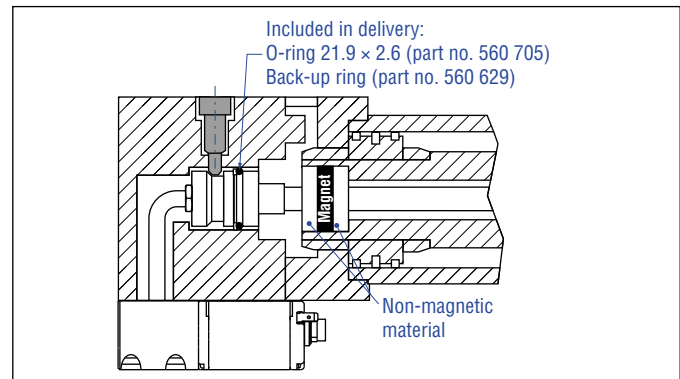

Fig. 19: Mounting example of pressure fit flange »S« and sensor electronics with bottom cable entry

Sensor electronics with side cable entry

Connect the rod via the cable to the sensor electronics on the side. Encapsulate the sensor system including the connection cables (Fig. 20). Note the bending radius of the cable if you run the cable between sensor electronics and rod (see Fig. 13).

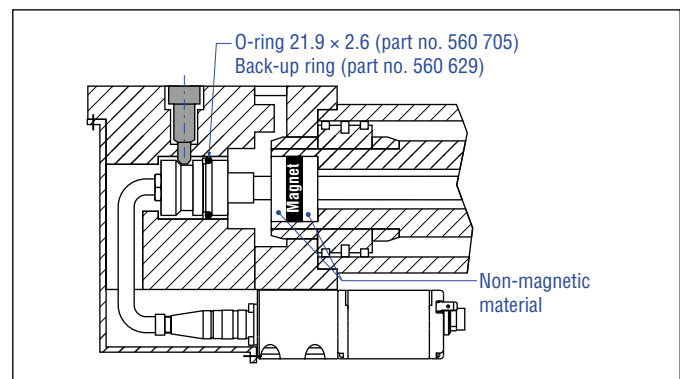

Fig. 20: Mounting example of pressure fit flange »S« and sensor electronics with side cable entry

Controlling design dimensions are in millimeters and measurements in () are in inches

NOTICE

To fulfill the EMC standards for emission and immunity the following points are necessary:

- The sensor electronics housing has to be connected to machine ground.
- The cable between the sensor and the electronics must be integrated into a metallic housing.

Connect the flange to the sensor electronics housing via the molex connectors for bottom cable entry respectively via the 6 pin cable for side cable entry.

Mounting of sensor electronics housing

Mount the sensor electronics housing with 4 M6×45 (ISO 4762) screws via the mounting block. Note the fastening torque of 6 Nm.

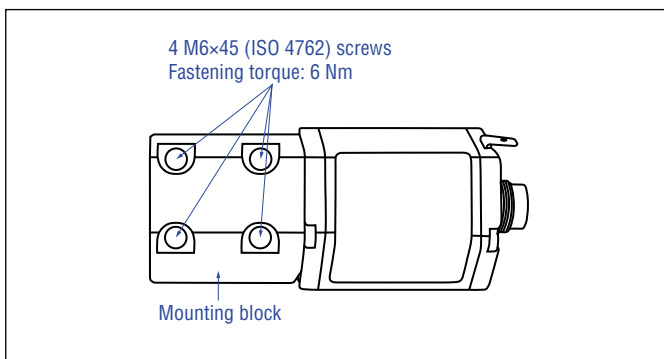
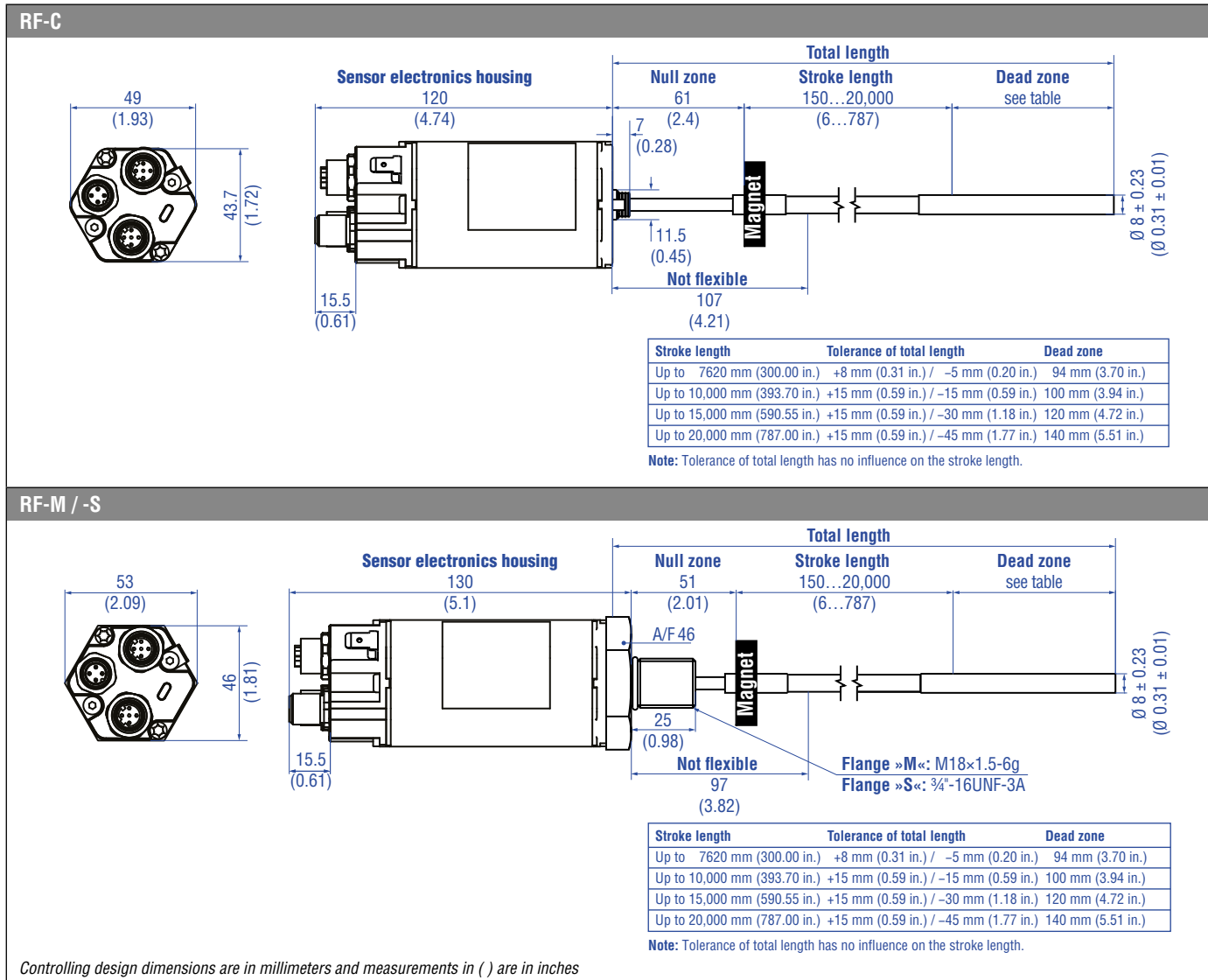

Fig. 21: Mounting of RD4's sensor electronics housing (example of bottom cable entry)

4.5 Styles and installation of Temposonics® RF



Controlling design dimensions are in millimeters and measurements in () are in inches

Fig. 22: Temposonics® RF base unit with ring magnet (top) and RF with threaded flange with ring magnet (bottom)

Note the following information when mounting a RF sensor:

1. Always insert the flexible sensor rod in a support tube (e.g. pressure rod HD / HL / HP or HFP profile). The support tube with an inside diameter of 9.4 mm (0.37 in.) consists of non-magnetic material. The support tube can be straight or bent (note the bending radius in Fig. 24).
2. Do never bend beyond the minimum bending radius of 250 mm (9.84 in.).

3. Note the minimum distance to a spatial limitation of 300 mm (11.81 in.), when mounting / dismantling the sensor (Fig. 24).
4. Note that the first 107 mm (4.21 in.) (for RF-C) respectively 97 mm (3.82 in.) (for RF-M) of the sensor rod are not flexible.

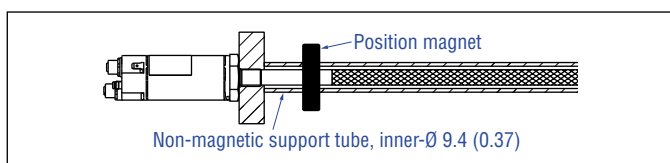

Fig. 23: Sensor with support tube

Controlling design dimensions are in millimeters and measurements in () are in inches

NOTICE

Smaller radiuses cause damage to the flexible sensor rod.

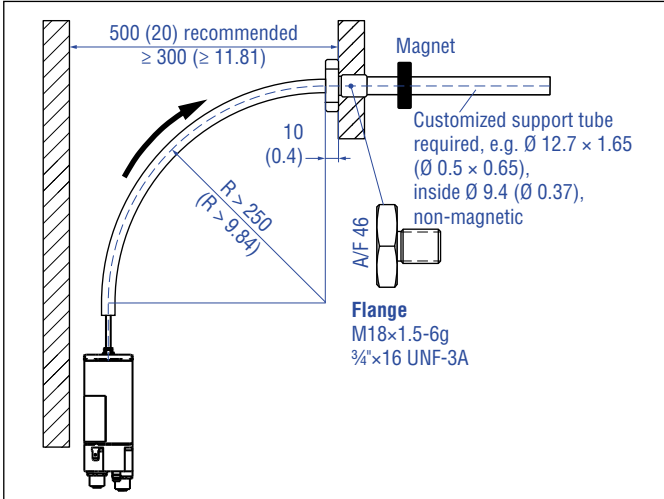

Fig. 24: Clearances for installation

This is the way you mount the RF sensors:

Sensor design	Mounting
RF-C	<ul style="list-style-type: none"> Insert the flexible sensor rod in a support tube. Mount the sensor electronics housing by means of two non-magnetic socket head screws M4x90. <p>Fastening torque: 2 Nm (see Fig. 25) <u>Recommendation:</u> Seal the sensor via flange.</p>
RF-C with pressure rod HD / HL / HP or HFP profile (see accessories)	<p><u>Advantage:</u> The flexible sensor rod is inserted in a support tube.</p> <ul style="list-style-type: none"> Mount the sensor electronics housing by means of two non-magnetic socket head screws M4x90. <p>Fastening torque: 2 Nm (see Fig. 25)</p>
RF-M / RF-S	<ul style="list-style-type: none"> Insert the flexible sensor rod in a support tube. Mount the sensor via flange.

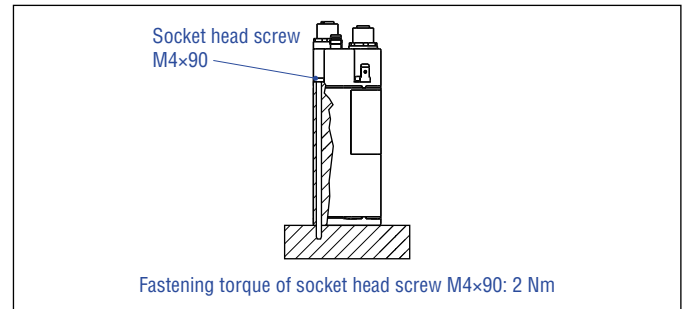

Fig. 25: Mounting with socket head screws M4x90

NOTICE

Connect the sensor electronics housing to machine ground to fulfill the EMC standards for emission and immunity.

Installation of RF with threaded flange »M«, »S« or RF with pressure rod HD / HL / HP

Fix the sensor rod via threaded flange M18x1.5-6g or 3/4"-16 UNF-3A.

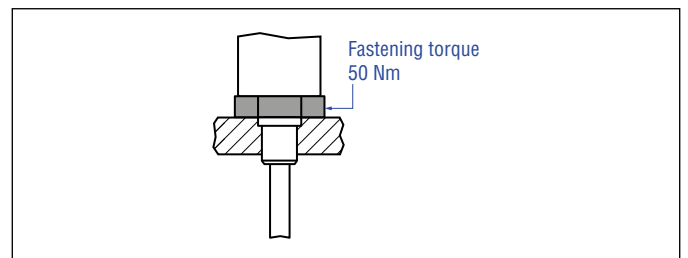

Fig. 26: Mounting example of threaded flange »M« / »S« or pressure rod HD / HL / HP

Installation of a RF sensor with pressure rod HD / HL / HP in a fluid cylinder:

The rod-style version has been developed for direct stroke measurement in a fluid cylinder. Mount the sensor via threaded flange or a hex nut.

- Mounted on the face of the piston, the position magnet travels over the rod without touching it and indicates the exact position through the rod wall – independent of the hydraulic fluid.
- The pressure resistant sensor rod is installed into a bore in the piston rod.
- The base unit is mounted by means of only two screws. It is the only part that needs to be replaced if servicing is required, i.e. the hydraulic circuit remains closed. For more information see chapter "4.7 Replacement of sensor" on page 26.

Hydraulics sealing when using a RF sensor in a pressure rod HD / HL / HP

There are two ways to seal the flange contact surface (Fig. 27):

1. A sealing by using an O-ring (e.g. 22.4 × 2.65 mm (0.88 × 0.1 in.), 25.07 × 2.62 mm (0.99 × 0.1 in.)) in a cylinder end cap groove.
2. A sealing by using an O-ring in the undercut.

For threaded flange (3/4"-16 UNF-3A) »S«:

O-ring 16.4 × 2.2 mm (0.65 × 0.09 in.) (part no. 560315)

For threaded flange (M18×1.5-6g) »M«:

O-ring 15.3 × 2.2 mm (0.60 × 0.09 in.) (part no. 401133)

In this case, a screw hole based on ISO 6149-1 (Fig. 28) must be provided. See ISO 6149-1 for further information.

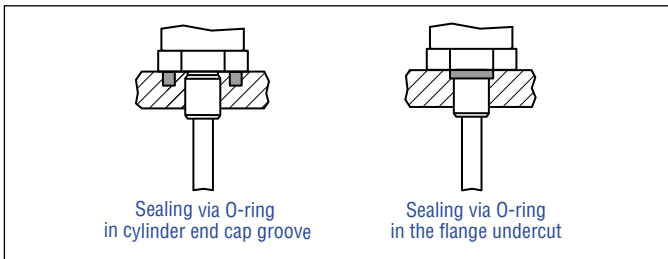

Fig. 27: Possibilities of sealing

Note the following points when using a RF-M / -S sensor or RF-C with pressure rod HD / HL / HP:

- Note the fastening torque of 50 Nm.
- Seat the flange contact surface completely on the cylinder mounting surface.
- The cylinder manufacturer determines the pressure-resistant gasket (copper gasket, O-ring, etc.).
- The position magnet should not grind on the sensor rod.
- The piston rod drilling for RF sensors with pressure rod (rod Ø 12.7 mm (0.5 in.)) is ≥ 16 mm (≥ 0.63 in.). The borehole depends on the pressure and piston speed.
- Adhere to the information relating to operating pressure.
- Protect the sensor rod against wear.

Notice for metric threaded flanges

Thread (d ₁ ×P)	d ₂	d ₃	d ₄	d ₅	L ₁	L ₂	L ₃	L ₄	Z°
				+0.1 0	+0.4 0				±1°
RF-M / optional pressure rod HD									
M18×1.5-6g	55	≥ 16	24.5	19.8	2.4	28.5	2	26	15°

Fig. 28: Notice for metric threaded flange M18×1.5-6g based on DIN ISO 6149-1

For additional information about optional accessories see:

- HFP Profile (document part number: 551442)
- Pressure rod HD / HL / HP (document part number: 551770)

4.6 Magnet installation





Magnet	Typical sensors	Benefits
 Ring magnets	Rod models (RH, RD4, RF)	<ul style="list-style-type: none"> Rotationally symmetrical magnetic field
 U-magnets	Profile & rod models (RP, RH, RD4, RF)	<ul style="list-style-type: none"> Height tolerances can be compensated
 Block magnets	Profile & rod models (RP, RH, RF)	<ul style="list-style-type: none"> The magnet can be lifted off Height tolerances can be compensated
 Magnet sliders	Profile models (RP)	<ul style="list-style-type: none"> The magnet is guided through the profile The distance between the magnet and the waveguide is strictly defined Easy coupling via the ball joint

Fig. 29: Typical use of magnets

Mounting ring magnets, U-magnets & block magnets

Install the magnet using non-magnetic material for mounting device, screws, spacers etc.. The magnet must not grind on the sensor rod. Alignment errors are compensated via the air gap.

- Permissible surface pressure: Max. 40 N/mm² (only for ring magnets and U-magnets)
- Fastening torque for M4 screws: 1 Nm; use washers, if necessary
- Minimum distance between position magnet and any magnetic material has to be 15 mm (0.6 in.) (Fig. 32).
- If no other option exists and magnetic material is used, observe the specified dimensions (Fig. 32).

NOTICE

Mount ring magnets and U-magnets concentrically. Mount block magnets centrally over the sensor rod or the sensor profile. Do not exceed the maximum acceptable gap (Fig. 30 / Fig. 31).

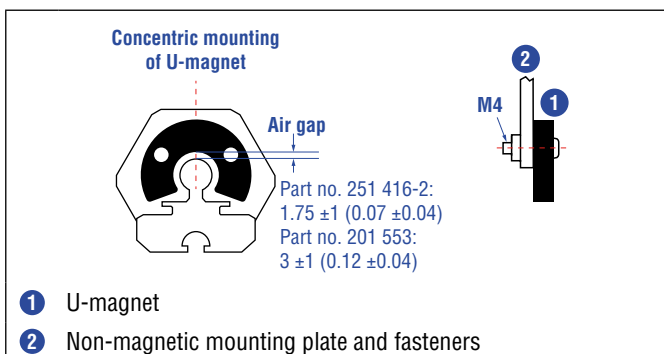

Fig. 30: Mounting of U-magnet (part no. 251 416-2 or part no. 201 553)

Controlling design dimensions are in millimeters and measurements in () are in inches

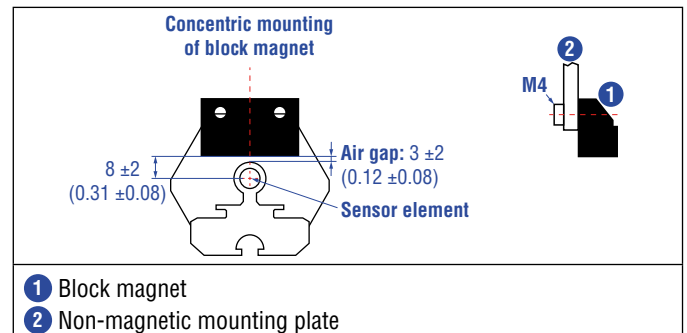

Fig. 31: Mounting of block magnet (part no. 403 448)

Magnet mounting with magnetic material

When using magnetic material the dimensions of Fig. 32 must be observed.

- If the position magnet aligns with the drilled piston rod
- If the position magnet is set further into the drilled piston rod, install another non-magnetic spacer (e.g. part no. 400 633) above the magnet.

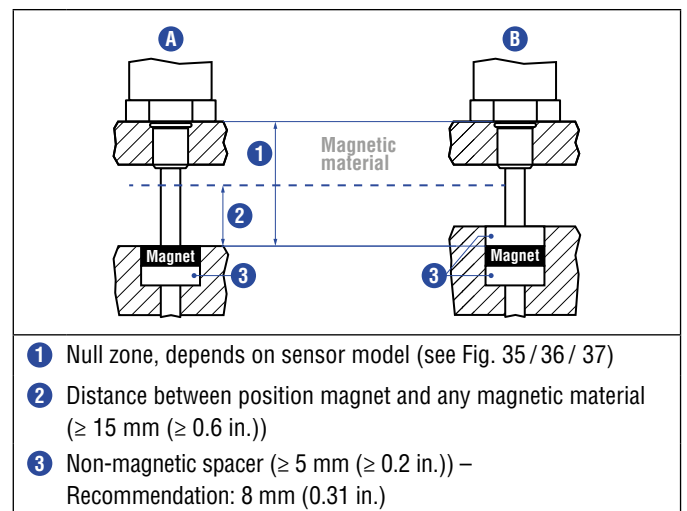

Fig. 32: Installation with magnetic material

Sensors with stroke lengths ≥ 1 meter (3.3 ft.)

Support horizontally installed sensors with a stroke length from 1 meter (3.3 ft.) mechanically at the rod end. Without the use of a support, rod and position magnet may be damaged. A false measurement result is also possible. Longer rods require evenly distributed mechanical support over the entire length (e.g. part no. 561 481). Use an U-magnet (Fig. 33) for measurement.

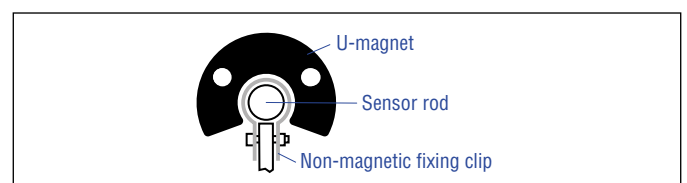

Fig. 33: Example of sensor support (part no. 561 481)

Start- and end positions of the position magnets

Consider the start and end positions of the position magnets during the installation. To ensure that the entire stroke length is electrically

usable, the position magnet must be mechanically mounted as follows.

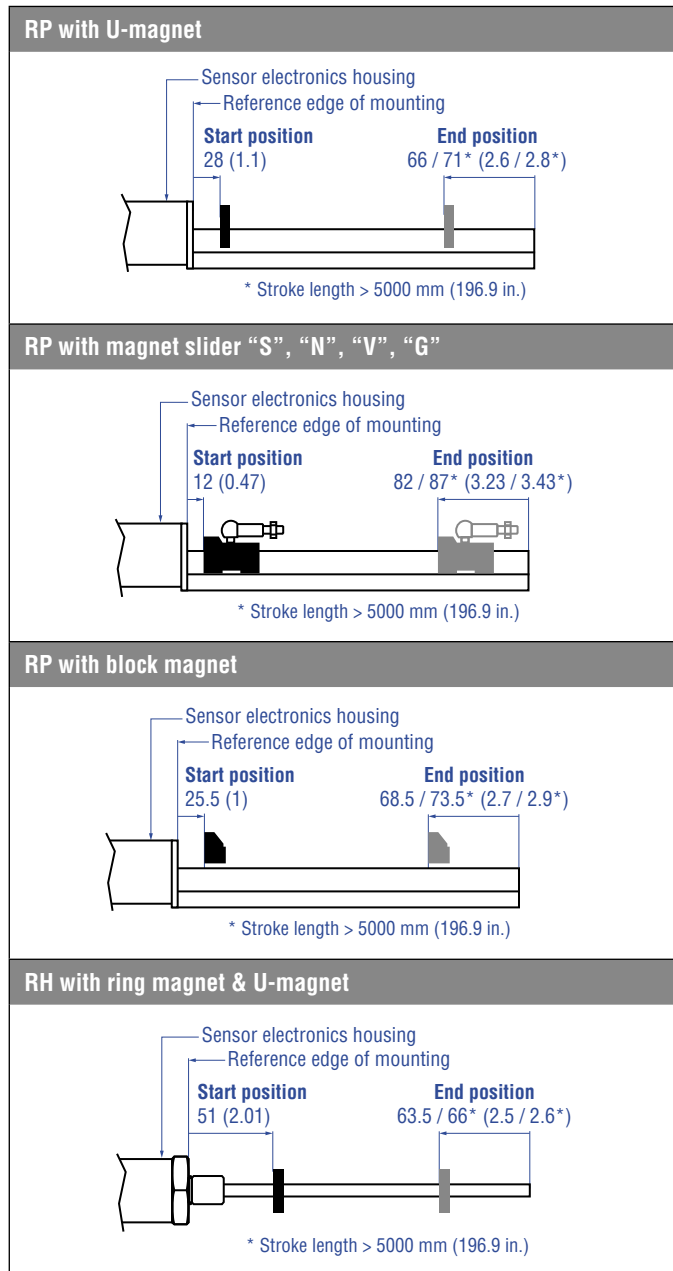

Fig. 34: Start- & end positions of magnets, part 1

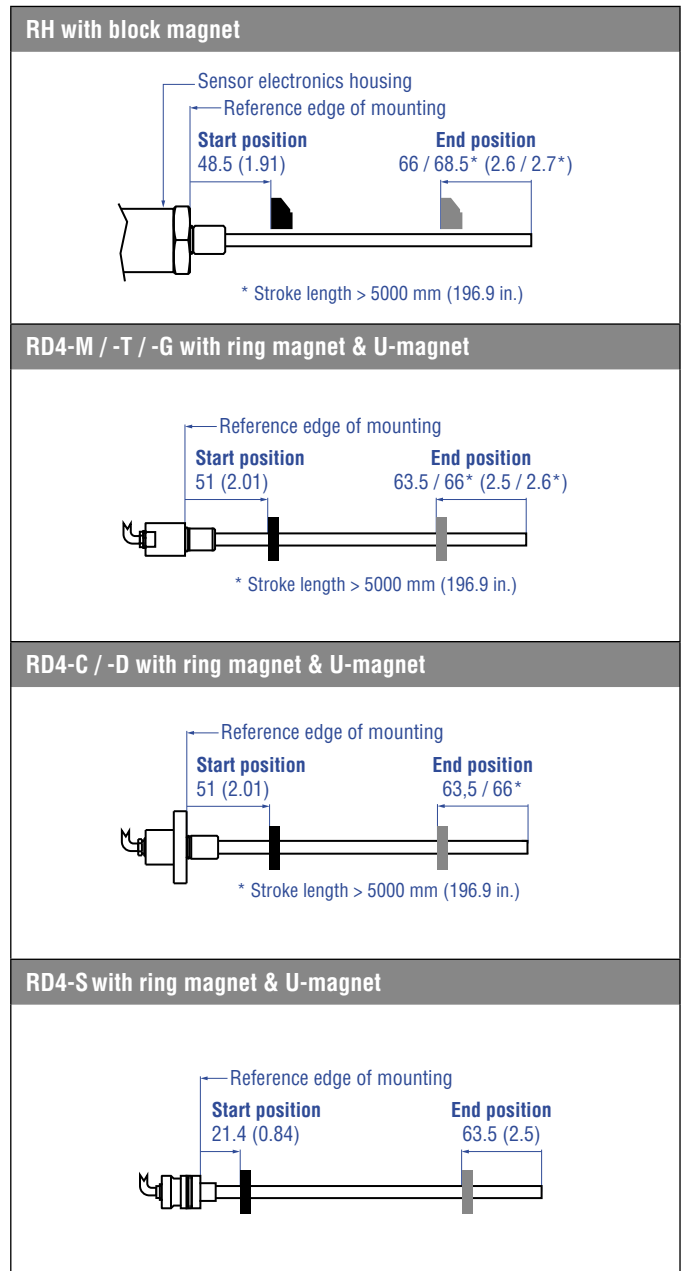

Fig. 35: Start- & end positions of magnets, part 2

Controlling design dimensions are in millimeters and measurements in () are in inches

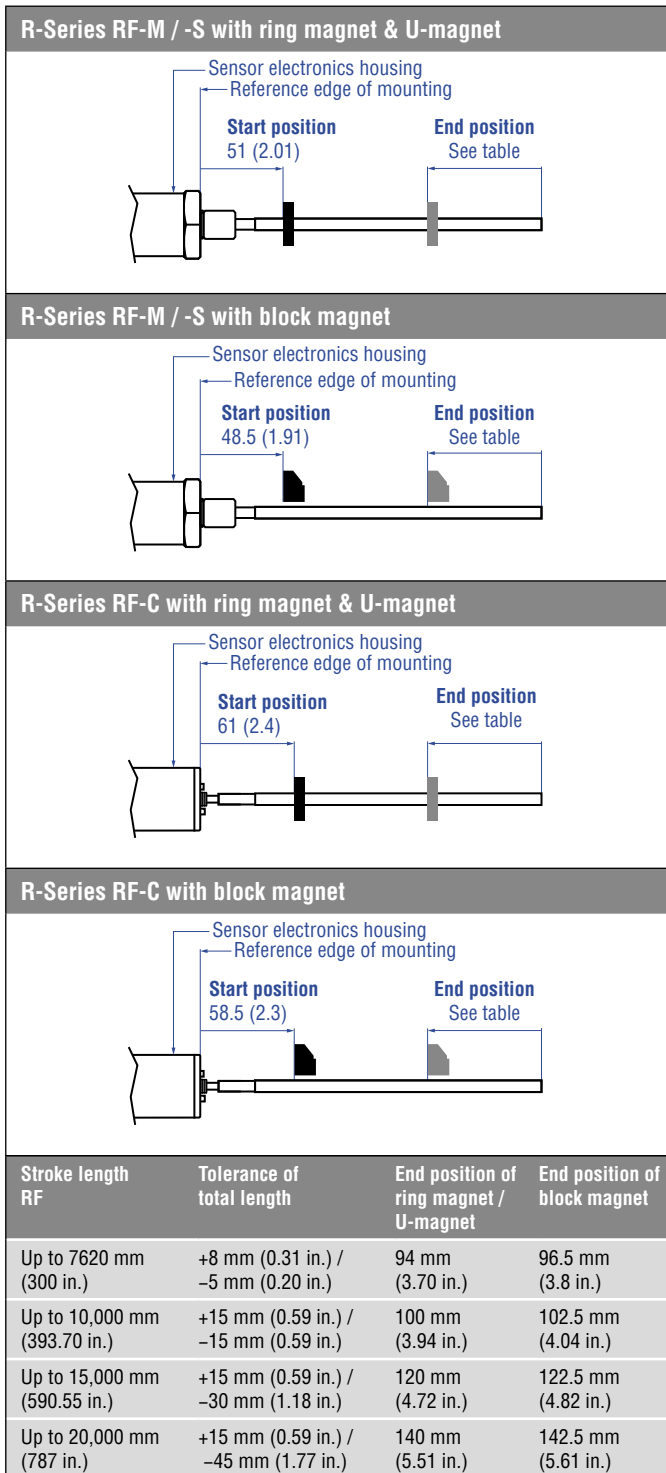

Fig. 36: Start- and end positions of magnets (Part 3)

NOTICE
On all sensors, the areas left and right of the active stroke length are provided for null and dead zone. These zones should not be used for measurement, but the active stroke length can be exceeded.

Multi-position measurement

The minimum distance between the magnets is 75 mm (3 in.).

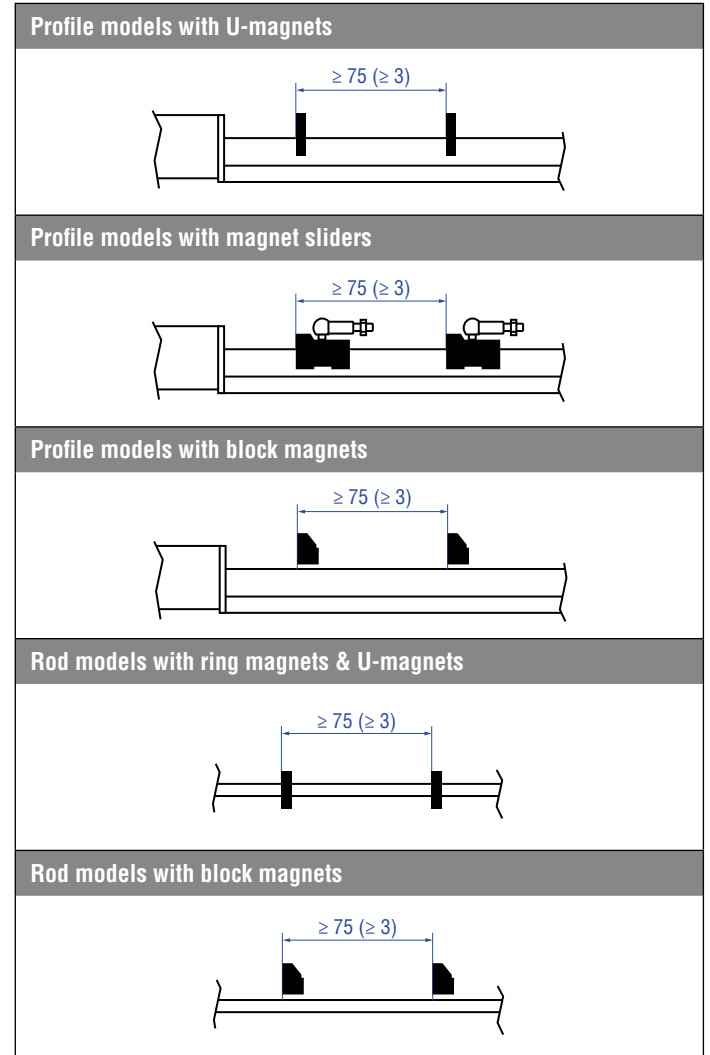

Fig. 37: Minimum distance for multi-position measurement

NOTICE
Use magnets of the same type (e.g. 2 ring magnets) for multi-position measurement. Do not go below a minimal distance of 75 mm (3 in.) between the magnets for multi-position measurement.*

*/ Contact MTS Sensors if you need a magnet distance, which is smaller than 75 mm (3 in.).

Controlling design dimensions are in millimeters and measurements in () are in inches

4.7 Replacement of sensor

The base unit of the sensor models RH (RH-B) and RF (RF-C) is replaceable as shown in Fig. 38 and Fig. 39. The sensor can be replaced without interrupting the hydraulic circuit.

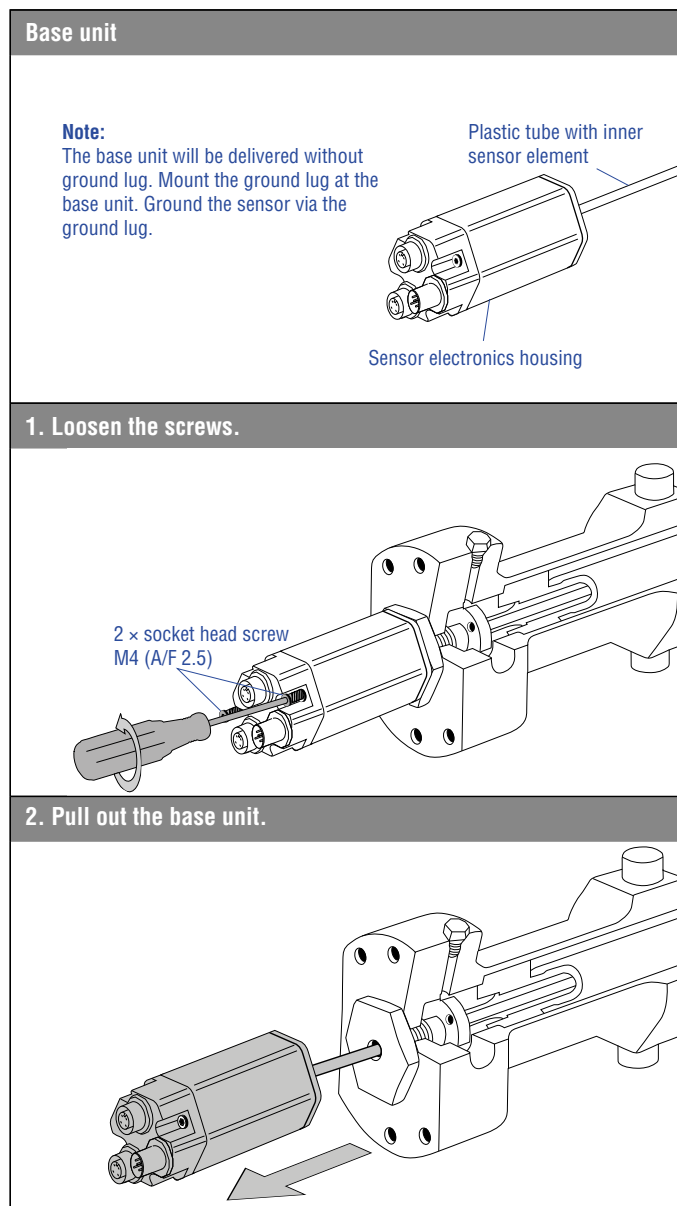

Fig. 38: Replacement of the base unit (e.g. RH sensor), part 1

- 3. Insert the new base unit.**
Mount the ground lug on a screw.
Tighten the screws.

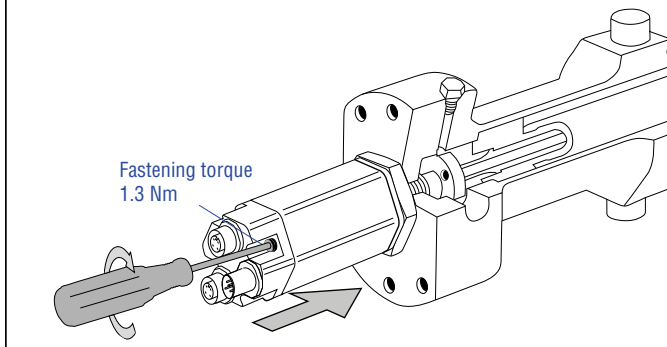

Fig. 39: Replacement of the base unit (e.g. RH sensor), part 2

NOTICE

- If necessary, the sensor electronics of sensor model RD4 can be replaced. Contact MTS Sensors for further information.
- Secure the base unit screws, e.g. using Loctite 243, before re-installing.

4.8 Electrical connections

Placement of installation and cabling have decisive influence on the sensor's electromagnetic compatibility (EMC). Hence correct installation of this active electronic system and the EMC of the entire system must be ensured by using suitable metal connectors, shielded cables and grounding. Overvoltages or faulty connections can damage its electronics despite protection against wrong polarity.

NOTICE

1. Do not mount the sensors in the area of strong magnetic or electric noise fields.
2. Never connect / disconnect the sensor when voltage is applied.

Instructions for connection

- Use low-resistant twisted pair and shielded cables. Connect the shield to ground externally via the controller equipment.
 - Keep control and signal leads separate from power cables and sufficiently far away from motor cables, frequency inverters, valve lines, relays, etc..
 - Use only connectors with metal housing and connect the shielding to the connector housing.
 - Keep the connection surface at both shielding ends as large as possible. Connect the cable clamps to function as a ground.
 - Keep all non-shielded leads as short as possible.
 - Keep the earth connection as short as possible with a large cross section. Avoid ground loops.
 - With potential differences between machine and electronics earth connections, no compensating currents are allowed to flow across the cable shielding.
- Recommendation:
Install potential compensating leads with large cross section, or use cables with separate double shielding, and connect only one end of the shield.
- Use only stabilized power supplies in compliance with the specified connecting values.

Grounding of profile and rod sensors

Connect the sensor electronics housing to machine ground. Ground sensor types RP, RH, RD4 and RF via ground lug as shown in Fig. 40. In addition you can ground the sensor type RH via thread.

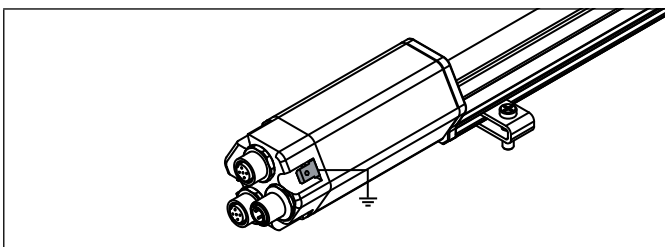

Fig. 40: Grounding via ground lug (e.g. profile sensor)

Connector wiring

Connect the sensor directly to the control system, indicator or other evaluating systems as follows:

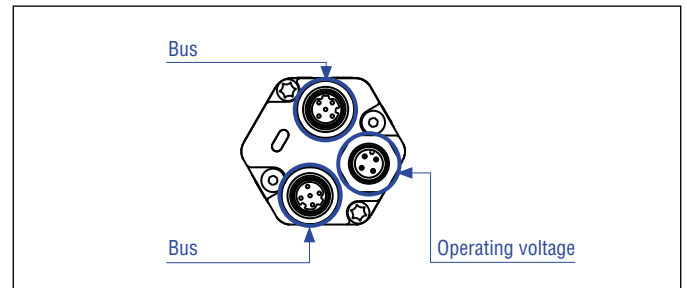
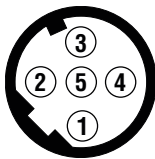
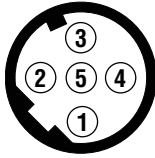
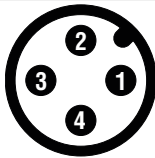

Fig. 41: Location of connections

D58		
Signal		
M12 female connector (D-coded)	Pin	Function
 View on sensor	1	Tx (+)
	2	Rx (+)
	3	Tx (-)
	4	Rx (-)
	5	Not connected
M12 female connector (D-coded)	Pin	Function
 View on sensor	1	Tx (+)
	2	Rx (+)
	3	Tx (-)
	4	Rx (-)
	5	Not connected
Power supply		
M12 male connector	Pin	Function
 View on sensor	1	+24 VDC (-15 / +20 %)
	2	Do not connect*
	3	DC Ground (0 V)
	4	Do not connect*

* As a connection to this pin may influence the correct startup of sensor

Fig. 42: Connector wiring D58

4.9 Frequently ordered accessories – Additional options available in our [Accessories Guide](#) 551 444

Position magnets

<p>Magnet slider S, joint at top Part no. 252 182</p> <p>For: RP</p> <p>Material: GFK, magnet hard ferrite Weight: Approx. 35 g Operating temperature: -40...+75 °C (-40...+167 °F)</p>	<p>Magnet slider V, joint at front Part no. 252 184</p> <p>For: RP</p> <p>Material: GFK, magnet hard ferrite Weight: Approx. 35 g Operating temperature: -40...+75 °C (-40...+167 °F)</p>	<p>U-magnet OD33 Part no. 251 416-2</p> <p>For: RP, RH, RD4</p> <p>Material: PA ferrite GF20 Weight: Approx. 11 g Surface pressure: Max. 40 N/mm² Fastening torque for M4 screws: 1 Nm Operating temperature: -40...+105 °C (-40...+221 °F)</p>	<p>Ring magnet OD33 Part no. 201 542-2</p> <p>For: RH, RD4, RF</p> <p>Material: PA ferrite GF20 Weight: Approx. 14 g Surface pressure: Max. 40 N/mm² Fastening torque for M4 screws: 1 Nm Operating temperature: -40...+105 °C (-40...+221 °F)</p>

Position magnets

<p>Ring magnet OD25.4 Part no. 400 533</p> <p>For: RH, RD4</p> <p>Material: PA ferrite Weight: Approx. 10 g Surface pressure: Max. 40 N/mm² Operating temperature: -40...+105 °C (-40...+221 °F)</p>	<p>Ring magnet Part no. 402 316</p> <p>For: RH, RD4, RF</p> <p>Material: PA ferrite coated Weight: Approx. 13 g Surface pressure: 20 N/mm² Operating temperature: -40...+100 °C (-40...+212 °F)</p>	<p>Block magnet L Part no. 403 448</p> <p>For: RP, RH, RD4</p> <p>Material: Hard ferrite Weight: Approx. 20 g Fastening torque for M4 screws: 1 Nm Operating temperature: -40...+75 °C (-40...+167 °F)</p>	<p>U-magnet OD63.5 Part no. 201 553</p> <p>For: RH, RD4, RF</p> <p>Material: PA 66-GF30, Magnets compound-filled Weight: Approx. 26 g Surface pressure: 20 N/mm² Fastening torque for M4 screws: 1 Nm Operating temperature: -40...+75 °C (-40...+167 °F)</p>

Magnet spacer



Sealings

<p>Magnet spacer Part no. 400 633</p> <p>For: RH, RD4</p> <p>Material: Aluminum Weight: Approx. 5 g Surface pressure: 20 N/mm² Fastening torque for M4 screws: 1 Nm</p>	<p>O-ring for flange M18x1.5-6g Part no. 401 133</p> <p>For: RH, RD4, RF</p> <p>Material: Fluoroelastomer 75 ± 5 durometer Operating temperature: -40...+204 °C (-40...+400 °F)</p>	<p>O-ring for flange 3/4"-16 UNF-3A Part no. 560 315</p> <p>For: RH, RD4, RF</p> <p>Material: Fluoroelastomer 75 ± 5 durometer Operating temperature: -40...+204 °C (-40...+400 °F)</p>	<p>O-ring for flange M22x1.5-6g Part no. 561 337</p> <p>For: RH</p> <p>Material: FPM 75 durometer Operating temperature: -20...+200 °C (-6...+392 °F)</p>

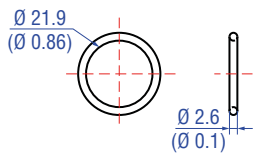
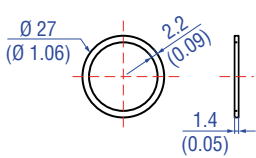
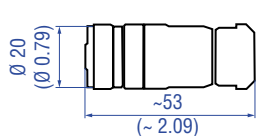
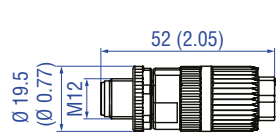
Sealing **Cable connectors⁹**

			
<p>O-ring for pressure fit flange Part no. 560 705</p>	<p>Back-up ring for pressure fit flange Part no. 560 629</p>	<p>M12 A-coded female connector (5 pin), straight Part no. 370 677</p>	<p>M12 D-coded male connector (4 pin), straight Part no. 370 523</p>
<p>For: RD4 Material: Nitrile rubber Operating temperature: -53...+107 °C (-65...+225 °F)</p>	<p>For: RD4 Application: Pressure fit flange Material: Polymyte 90 durometer</p>	<p>Material: GD-Zn, Ni Termination: Screw Contact insert: CuZn Cable Ø: 4...8 mm (0.16...0.31 in.) Wire: 1.5 mm² Operating temperature: -30...+85 °C (-22...+185 °F) Ingress protection: IP67 (correctly fitted) Fastening torque: 0.6 Nm</p>	<p>Material: Zinc nickel-plated Termination: Insulation-displacement Cable Ø: 5.5...7.2 mm (0.2...0.28 in.) Operating temperature: -25...+85 °C (-13...+185 °F) Ingress protection: IP65/IP67 (correctly fitted) Fastening torque: 0.6 Nm</p>

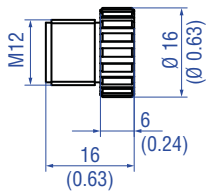

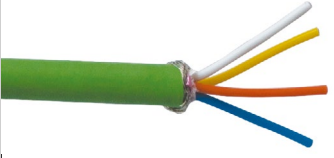

Accessory for M12 cable connector **Cables**

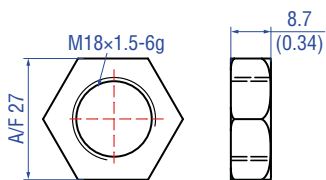
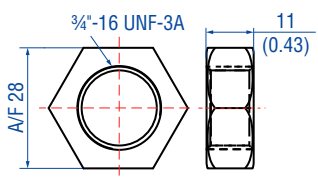
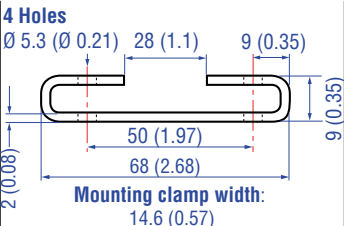
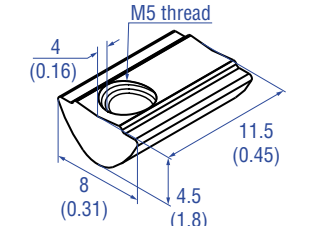

			
<p>M12 connector end cap Part no. 370 537</p>	<p>Cable with M12 D-coded male connector – M12 D-coded, male connector, 5 m (16.4 ft.) Part no. 530 064</p>	<p>Cable with M12 D-coded male connector – RJ45 male connector, 5 m (16.4 ft.) Part no. 530 065</p>	<p>PUR cable Part no. 530 125</p>
<p>Female connectors M12 should be covered by this protective cap Material: Brass nickel-plated Ingress protection: IP67 (correctly fitted) Fastening torque: 0.39...0.49 Nm</p>	<p>Material: PUR jacket; green Features: Cat 5e Cable length: 5 m (16.4 ft.) Cable Ø: 6.5 mm (0.26 in.) Ingress protection: IP65, IP67, IP68 (correctly fitted) Operating temperature: -30...+70 °C (-22...+158 °F)</p>	<p>Material: PUR jacket; green Features: Cat 5e Cable length: 5 m (16.4 ft.) Cable Ø: 6.5 mm (0.26 in.) Ingress protection M12 connector: IP67 (correctly fitted) Ingress protection RJ45 connector: IP20 (correctly fitted) Operating temperature: -30...+70 °C (-22...+158 °F)</p>	<p>Material: PUR jacket; green Features: Cat 5 Cable Ø: 6.5 mm (0.26 in.) Dimensions: 2×2×0.35 mm² (22/7 AWG) Operating temperature: -20...+60 °C (-4...+140 °F)</p>

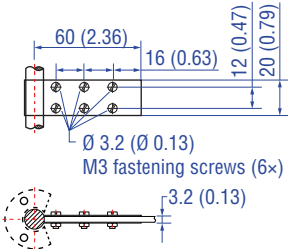
Mounting hardware

			
<p>Hex jam nut M18×1.5-6g Part no. 500 018</p>	<p>Hex jam nut 3/4"-16 UNF-3A Part no. 500 015</p>	<p>Mounting clamp Part no. 400 802</p>	<p>T-slot nut Part no. 401 602</p>
<p>For: RH, RD4, RF Material: Steel, zinc, plated</p>	<p>For: RH, RD4, RF Material: Zinc plated with nylon insert</p>	<p>For: RP Material: Stainless steel (AISI 304)</p>	<p>For: RP Fastening torque for M5 screw: 4.5 Nm</p>

^{9/} Follow the manufacturer's mounting instructions
Controlling design dimensions are in millimeters and measurements in () are in inches

Mounting hardware	Pressure rods (RF)		
			
<p>Fixing clip Part no. 561 481</p>	<p>Pressure rod with flange M18×1.5-6g (flat-faced flange) and O-ring HL [length mm: XXXX] M HD [length mm: XXXX] M HD [length in.: XXX.X] U</p>	<p>Pressure rod with flange ¾"-16 UNF-3A (flat-faced flange) and O-ring HL [length mm: XXXX] M HL [length in.: XXX.X] U</p>	<p>Pressure rod with flange ¾"-16 UNF-3A (raised-faced flange) and O-ring HP [length mm: XXXX] M HP [length in.: XXX.X] U</p>
<p>For: RH, RD4</p> <p>Application: Used to secure sensor rods (Ø 10 mm (Ø 0.39 in.)) when using an U-magnet</p> <p>Material: Brass, non-magnetic</p>	<p>For: RF-C</p> <p>Pressure rod Ø: 12.7 mm (0.5 in.) Length: 255...7500 mm (10...295 in.) Operating pressure: 350 bar (5076 psi)</p> <p>Material flange: Stainless steel 1.4305 (AISI 303)</p> <p>Material rod: Stainless steel 1.4301 (AISI 304)</p> <p>See technical bulletin "RF pressure housing pipe" (document part no.: 551 770) for further information</p>	<p>For: RF-C</p> <p>Pressure rod Ø: 12.7 mm (0.5 in.) Length: 255...7500 mm (10...295 in.) Operating pressure: 350 bar (5076 psi)</p> <p>Material flange: Stainless steel 1.4305 (AISI 303)</p> <p>Material rod: Stainless steel 1.4301 (AISI 304)</p> <p>See technical bulletin "RF pressure housing pipe" (document part no.: 551 770) for further information</p>	<p>For: RF-C</p> <p>Pressure rod Ø: 12.7 mm (0.5 in.) Length: 255...7500 mm (10...295 in.) Operating pressure: 350 bar (5076 psi)</p> <p>Material flange: Stainless steel 1.4305 (AISI 303)</p> <p>Material rod: Stainless steel 1.4301 (AISI 304)</p> <p>See technical bulletin "RF pressure housing pipe" (document part no.: 551 770) for further information</p>

Flanges (RF)	Profile (RF)	
		
<p>Flange M18×1.5-6g Part no. 402 704</p>	<p>Flange ¾"-16 UNF-3A Part no. 402 641</p>	<p>Profile with flange HFP [length mm: XXXXX] M HFP [length in.: XXXX.X] U</p>
<p>For: RF-C</p> <p>Material: Stainless steel 1.4305 (AISI 303)</p>	<p>For: RF-C</p> <p>Material: Stainless steel 1.4305 (AISI 303)</p>	<p>For: RF-C</p> <p>Length: Max. 20 000 mm (max. 787 in.) Ingress protection: IP30 Material: Aluminum See "Product Flash RF Profile" (Document Part No.: 551 442) for further information</p>

Manuals & Software available at:
www.mtssensors.com

5. Operation

5.1 Getting started

The sensor is factory-set to its order sizes and adjusted, i.e. the required output signal corresponds exactly to the selected stroke length.

Example: Output Profinet IO RT = 0...100 % stroke length

Diagnostic display

(Red / green) LEDs in the sensor electronics housing lid provide information on the current sensor condition.

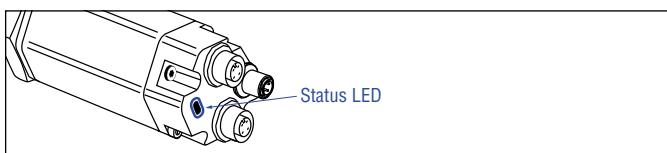

Fig. 43: LED display

Profinet LED status				
Green	Red	Information		
● ON	○ OFF	Normal function		
● ON	● ON	No connection to master		
● ON	◐ Flashing	Parameterization failed		
○ OFF	● ON	Warning! (illegal supply voltage / wrong quantity of magnets)		

NOTICE

Observe during commissioning

1. Before initial switch-on, check carefully if the sensor has been connected correctly.
2. Position the magnet in the measuring range of the sensor during first commissioning and after replacement of the magnet.
3. Ensure that the sensor control system cannot react in an uncontrolled way when switching on.
4. Ensure that the sensor is ready and in operation mode after switching on. The bus status LED lights permanently green.
5. Check the preset span start and end values of the measuring range (see chapter 4.6) and correct them via the customer's control system, if necessary.

Following network protocols are supported:

- RTC (Class1) (Real Time Cyclic Protocol):
Protocol for cyclic IO data (process data and measured values)
- RTA (Real Time Acyclic Protocol):
Protocol for acyclic real time data (e.g. alarms)
- DCP (Discover and Basic Configuration Protocol):
Assignment of IP configuration and device name
- DCE/RPC (Distributed Computing Environment Remote Procedure Call):
Remote Procedure Calls via IP (e.g. parameter configuration)
- LLDP (Link Layer Discovery Protocol):
Protocol used for neighborhood detection
- SNMP (Simple Network Management Protocol):
Protocol used for network node diagnosis
- MRP (Media Redundancy Protocol):
Searches for alternative routes in case of cable error or node error

6. Programming and configuration

Software configuration

These instructions describe the installation and configuration of a MTS Profinet IO RT sensor using a CP1616 Profinet IRT controller and a Siemens projecting tool (SIMATIC NCM Manager, version 5.5).

Installing the software and the network card

Depending on control system type.

The following figures are taken from the Siemens SIMATIC NC Manager documentation.

6.1 Configuration of the network interface

- Step 1: Configuration of the network interface**
- Step 2: Configuration of the sensor designation
- Step 3: Controller setting and preparation of the network
- Step 4: Integration of GSDML files (of the sensor)
- Step 5: Integration and configuration of the sensors
 - a) with U402 profile (MTS profile)
 - b) with U401 profile (encoder profile 4.1)

For communication with the Profinet network, an ethernet connection with corresponding configuration must be selected.

1. Select "Options" → "Set PG/PC Interface" (Fig. 44):

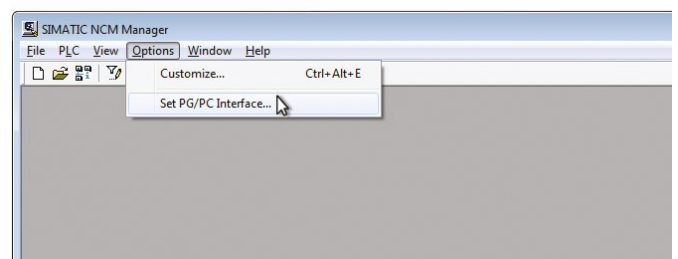

Fig. 44: Set PG/PC Interface (source: Siemens)

2. Select a connection from the list, which is connected with CP1616, and click “OK” to confirm (Fig. 45).

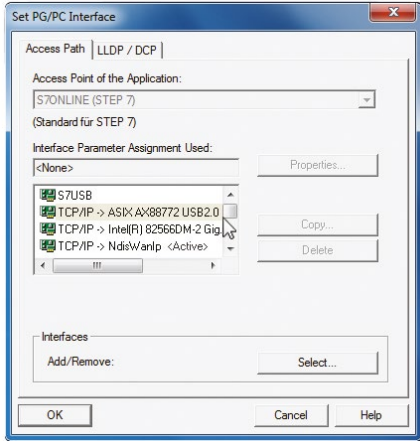

Fig. 45: Set PG/PC Interface (source: Siemens)

Note that the selected interface is configured in the same IP subnet as the CP1616 unit and that the following protocols are activated: QoS package planner, Profinet IO RT protocol V2.0, network monitor drivers, Internet protocol (TCP/IPv4).

6.2 Configuration of the sensor designation

- Step 1: Configuration of the network interface
- Step 2: Configuration of the sensor designation**
- Step 3: Controller setting and preparation of the network
- Step 4: Integration of GSDML files (of the sensor)
- Step 5: Integration and configuration of the sensors
 - a) with U402 profile (MTS profile)
 - b) with U401 profile (encoder profile 4.1)

For clear sensor identification in the network, a sensor designation must be assigned. This is done in the NCM Manager.

1. Select the MTS R-Series Profinet IO RT sensor as described below (Fig. 46):
 - PLC
 - Edit Ethernet Node
 - Browse (Fig. 47)

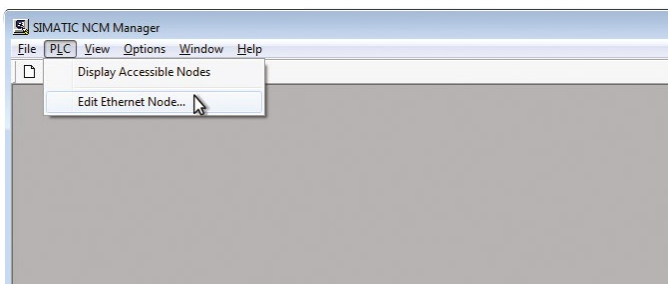

Fig. 46: Select the MTS R-Series Profinet sensor (step 1) (source: Siemens)

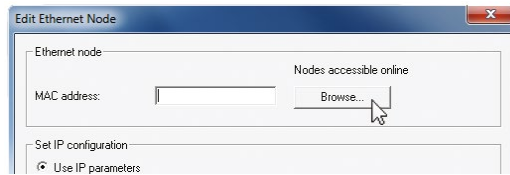

Fig. 47: Select the MTS R-Series Profinet sensor (step 2) (source: Siemens)

2. Select a sensor from the list to which a name must be assigned. A sensor is identified by the type designation “MTS-R-SERIES-PROFINET” and a “MAC address prefix 00-03-CA”. Click “OK” to confirm your selection (Fig. 48).

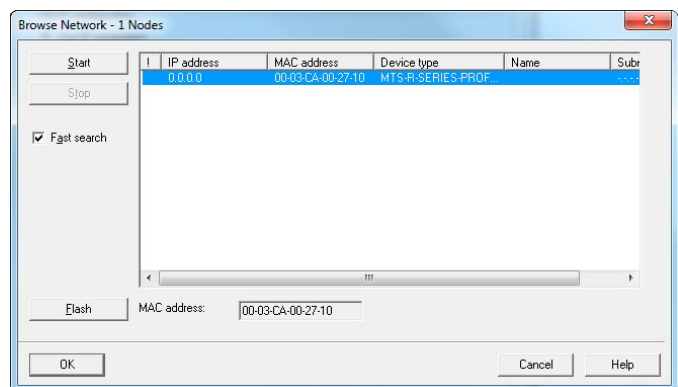

Fig. 48: List of available Profinet IO devices (source: Siemens)

3. Assign a device name and confirm your entry with “Assign name” (Fig. 49).

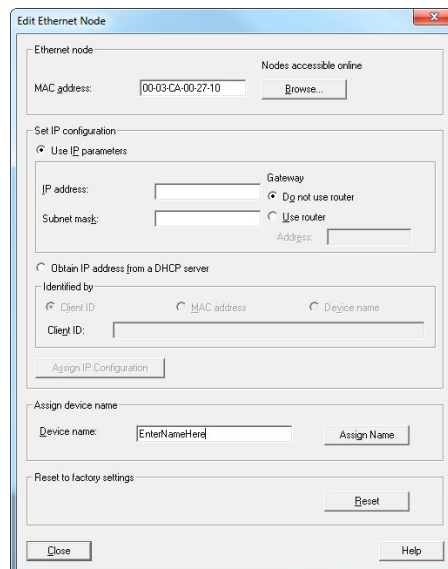

Fig. 49: Select the MTS R-Series Profinet sensor (step 3) (source: Siemens)

6.3 Controller setting and preparation of the network

- ✓ Step 1: Configuration of the network interface
- ✓ Step 2: Configuration of the sensor designation
- Step 3: Controller setting and preparation of the network
- Step 4: Integration of GSDML files (of the sensor)
- Step 5: Integration and configuration of the sensors
 - a) with U402 profile (MTS profile)
 - b) with U401 profile (encoder profile 4.1)

1. Start the SIMATIC NCM Manager to configure the Profinet IO RT network.

2. Create a new project under “File” → “New” (Fig. 50). Subsequently, select the “Name” and the “Path” of the project file (Fig. 51).

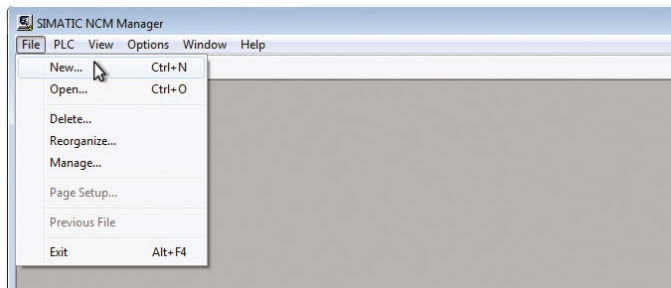

Fig. 50: Create a new project (source: Siemens)



Fig. 51: Assign a project name and a memory location (source: Siemens)

Click “OK” to confirm your entry. After creating the project, the project overview opens, which will be filled with components when proceeding (Fig. 52).

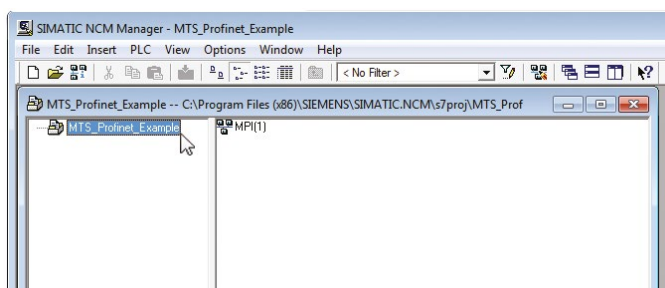

Fig. 52: Project overview (source: Siemens)

3. Add a controller to the project. For this, proceed as described below (Fig. 53):

- Right-click project (MTS_Profinet_Example)
- Insert new object
- Select the SIMATIC PC Station

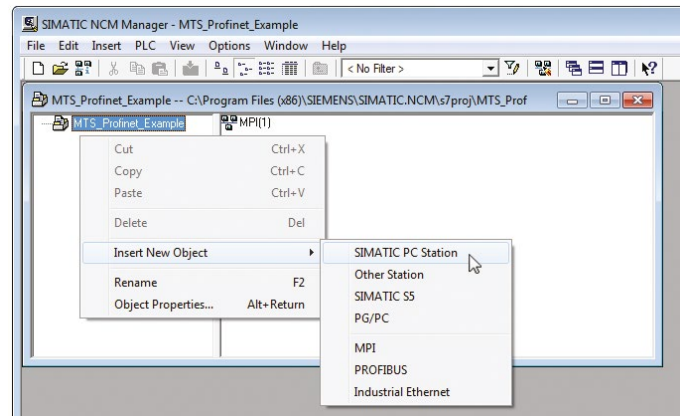

Fig. 53: Add a controller to the project (source: Siemens)

The SIMATIC PC station (controller) is displayed in the right area of the project overview. Double-click the SIMATIC PC station to display the controller in the left area of the project overview (Fig. 54).

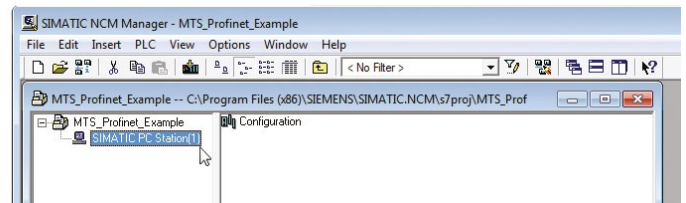

Fig. 54: Controller link to project (source: Siemens)

4. Double-click “Configuration” with the “Station” selected to open the window “Module HW Config” to determine the network and sensor configuration (Fig. 55).

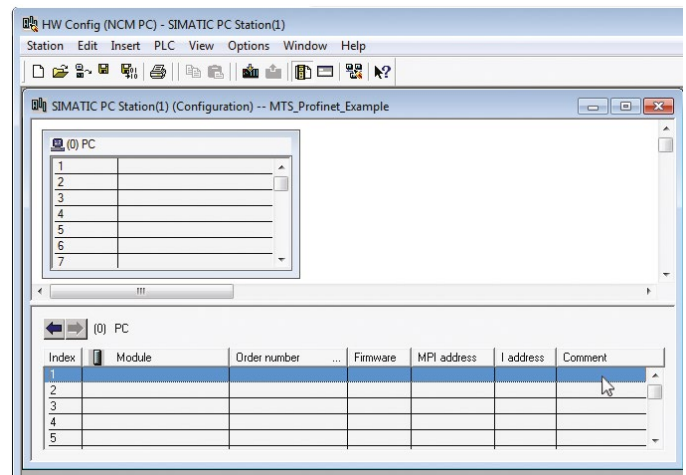

Fig. 55: Module HW Config (source: Siemens)

5. Right-click to insert the network controller, as described below:

- Insert Object (Fig. 56)
- CP Industrial Ethernet (Fig. 57)
- CP1616 (Fig. 58)

Select the appropriate firmware version of your CP1616.

The dialog box “Properties – Ethernet interface” opens (Fig. 58). Set the IP address of your CP1616.

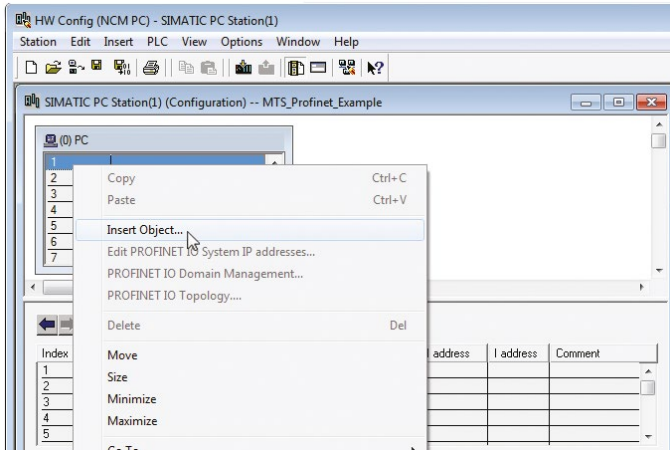

Fig. 56: Insert controller into the network (step 1) (source: Siemens)

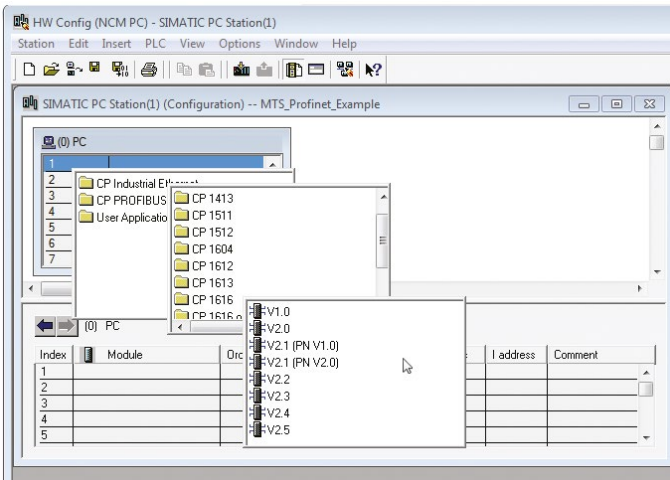

Fig. 57: Insert controller into the network (step 2) (source: Siemens)

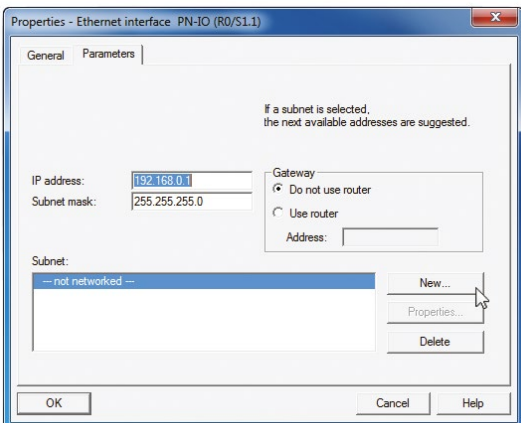

Fig. 58: Set IP address of CP1616 (source: Siemens)

6. To create a subnet, click button “New” (Fig. 58). Window “Properties – New subnet” opens (Fig. 59). Define a name and click “OK” to confirm your entry.

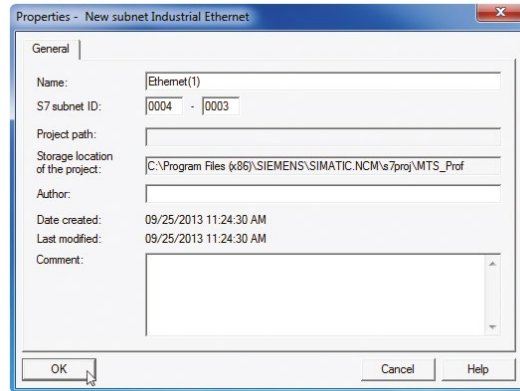

Fig. 59: Create a subnet (source: Siemens)

7. A network without sensors has been configured (Fig. 60).

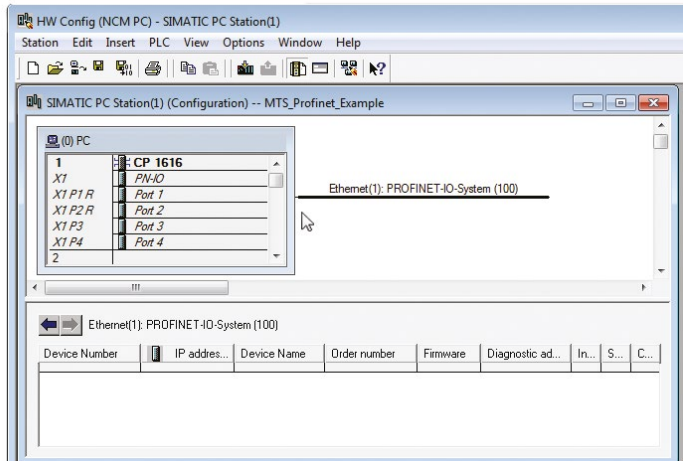

Fig. 60: Configuration of network without sensors (source: Siemens)

6.4 Integration of GSDML files (of the sensor)

- ✓ Step 1: Configuration of the network interface
- ✓ Step 2: Configuration of the sensor designation
- ✓ Step 3: Controller setting and preparation of the network
- Step 4: Integration of GSDML files (of the sensor)
- Step 5: Integration and configuration of the sensors
 - a) with U402 profile (MTS profile)
 - b) with U401 profile (encoder profile 4.1)

To operate the sensor in a network, the sensor data is loaded from the GSDML file into the controller.

1. For this purpose, select the following options in window "HW Config" (Fig. 61):

- Options
- Install GSD file

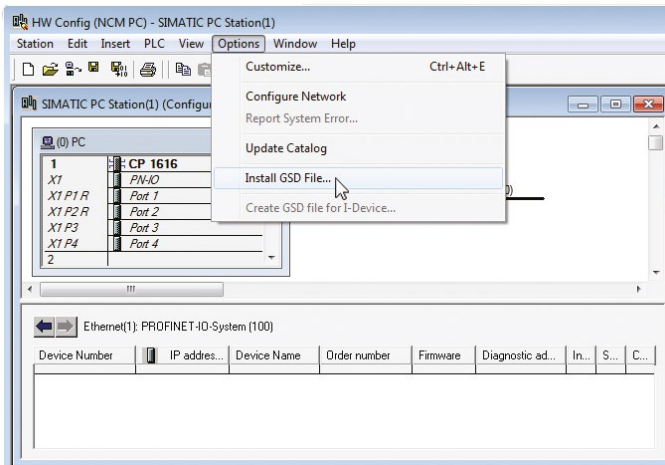

Fig. 61: HW Config (source: Siemens)

NOTICE

The U401¹⁰ profile (encoder Profile 4.1) fulfills the requirements and functionality according to the encoder profile V4.1 (PNO no. 3162). The U402¹⁰ profile (MTS profile) is a system developed by MTS Sensors for capturing position or velocity of up to 19 magnets. U401 and U402 are output choices of the order code.

2. Window "Install GSD File" is opened. Click button "Browse" to select one of the following GSD files (available at www.mtssensors.com):

- U402 profile (MTS profile) (GSDML)
- U401 profile (Encoder profile 4.1) (GSDML)

6.5 Integration and configuration of the sensors with MTS profile

- ✓ Step 1: Configuration of the network interface
- ✓ Step 2: Configuration of the sensor designation
- ✓ Step 3: Controller setting and preparation of the network
- ✓ Step 4: Integration of GSDML files (of the sensor)
- Step 5: Integration and configuration of the sensors
 - a) with U402 profile (MTS profile)
 - b) with U401 profile (encoder profile 4.1)

1. Select the MTS communication protocol from the directory displayed on the right (Fig. 62).

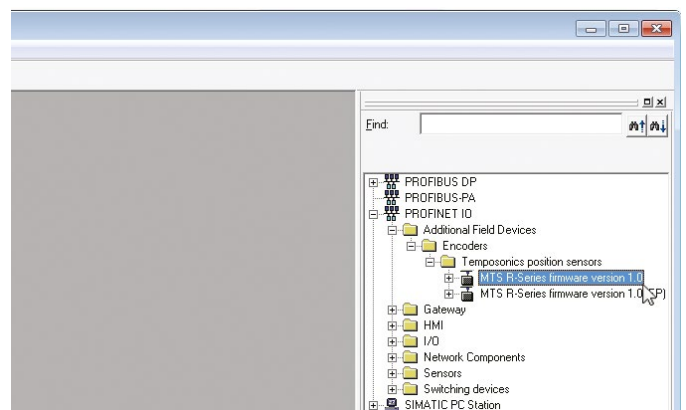

Fig. 62: Select MTS communication protocol (source: Siemens)

2. Select for U402 profile the file "MTS R-Series firmware version 1.0". Drag and drop this file from the directory into the network (dashed line). The sensor has been added to the network (Fig. 63).

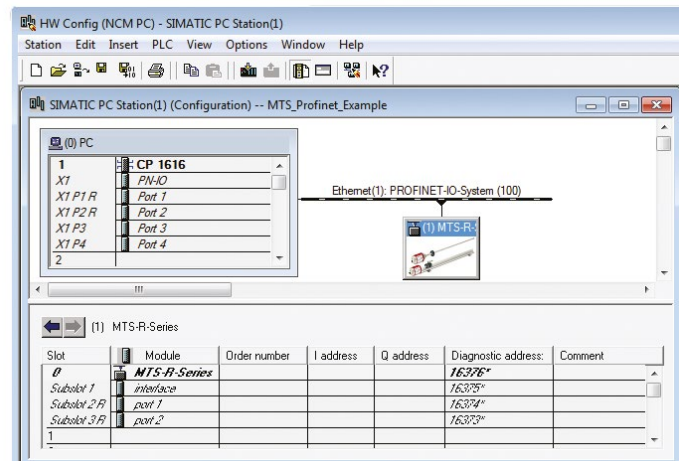

Fig. 63: Add sensor to the network (source: Siemens)

¹⁰ Depending on the integrated profile

3. Double-click on the MTS R-Series icon to select the sensor and enter the previously defined name into field "Device name". Press "OK" to confirm your entries.
4. Double-click Slot "0" to open a configuration dialog box (Fig. 64).

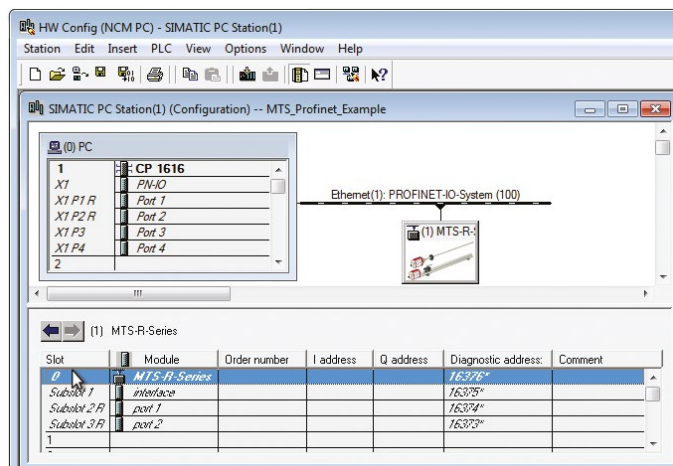

Fig. 64: HW Config-Window (Source: Siemens)

Select tab "Parameters" to realize the following sensor settings (Fig. 65):

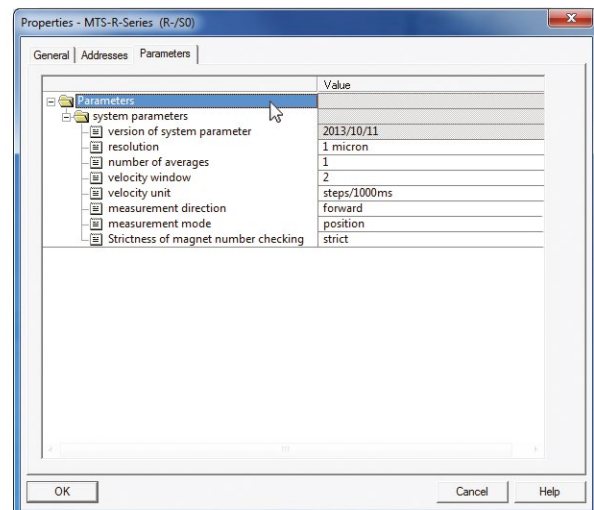

Fig. 65: Properties – MTS-R-Series (Source: Siemens)

- a) **Resolution:**
Specifies the resolution for position measurement.
Possible values: 1, 2, 5, 10, 50, 100 µm
- b) **Number of averages:**
Specifies the number of values to form an average value.
Possible values: 1, 2, 4, 8
- c) **Velocity window:**
Specifies number of position values for determining the speed of the position magnet.
Possible values: 2, 4, 8, 16
- d) **Velocity unit:**
Specifies the unit of velocity output.
Possible values: steps/s, steps/100ms, steps/10ms, mm/s
- e) **Measurement direction:**
Specifies the measurement direction for position measurement.
Possible values:
Forward (from the sensor electronics housing to the rod end)
Reverse (from the rod end to the sensor electronics housing)
- f) **Measurement mode:**
Specifies the mode of the output value: position or velocity.
Possible values: position/velocity
- g) **Strictness:**
Specifies an error display in multi magnetic measurements.
Possible values:
Strict: Error display, when the number of magnets on the sensor ≠ Number of ordered magnets (ZXX)
None: No error display, if the number of magnets < number of ordered magnets (ZXX)
Loose: An error displays, if the number of magnets is outside of the range shown in the table below.

Ordered magnets (ZXX)	Minimum number of magnets	Maximum number of magnets
01	1	1
02	2	2
03	2	3
04	3	4
05	4	5
06	4	6
07	5	7
08	6	8
09	6	9
10	7	10
11	7	11
12	8	12
13	9	13
14	10	14
15	10	15
16	11	16
17	12	17
18	12	18
19	13	19

The system displays an error message for all three values of the parameter "strictness" if the number of magnets on the sensor is higher than the ordered number of magnets. In addition, a warning is given when the used number of magnets is different from the projected number of magnets.

1. Double-click Slot "0" → Subslot "1" (Interface) (Fig. 66).
Go to tab "IO Cycle" to enter the cycle time setting (Fig. 67).

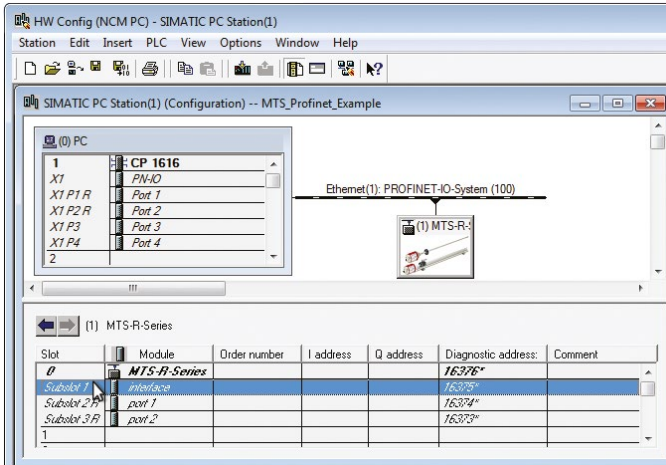

Fig. 66: HW Config (source: Siemens)

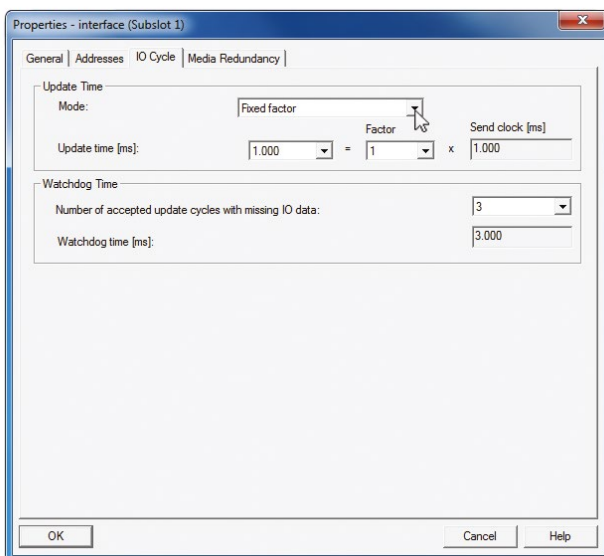

Fig. 67: Properties – interface (Subslot 1) (source: Siemens)

2. Add the number of magnets specified in your order as described below: – Right-click Slot 1 (Fig. 68)
 - Insert Object (Fig. 68)
 - MTS R-Series Firmware Version X
 - Magnet (Fig. 69)
 To add another magnet, repeat the steps described under item 6 for Slot 2, etc..

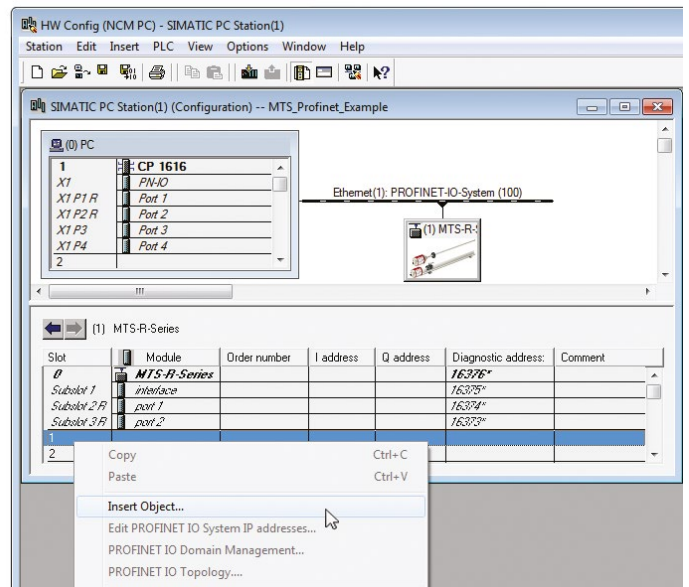

Fig. 68: Insert object (source: Siemens)

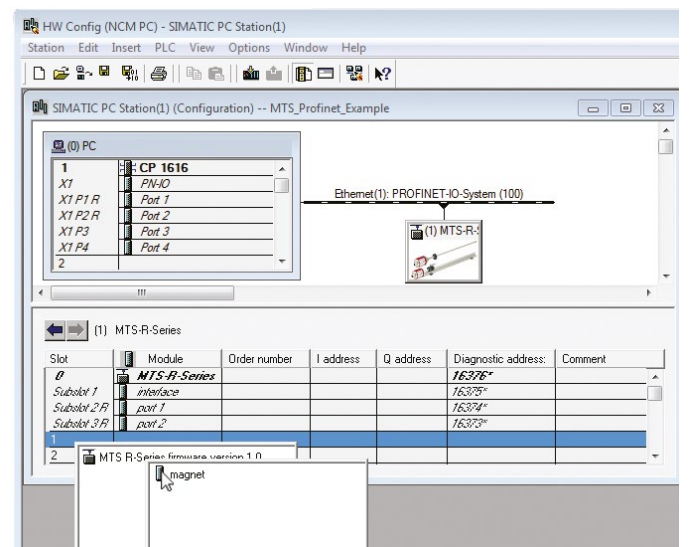

Fig. 69: Add magnet (source: Siemens)

- Double-click a magnet to open window “Properties – magnet”. Select tab “Parameters” and adjust the position offset of the magnet with unit μm (Fig. 70).

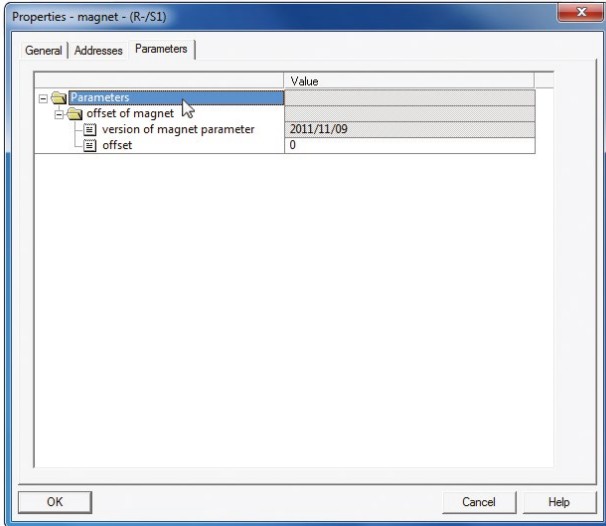

Fig. 70: Adjust the position offset of the magnet (source: Siemens)

- Transfer your settings to the controller as described below (Fig. 71):
 - PLC
 - Download
 - CP1616

From your control program, you can now access the position data of the first magnet, etc., via addresses 512...515 (example).

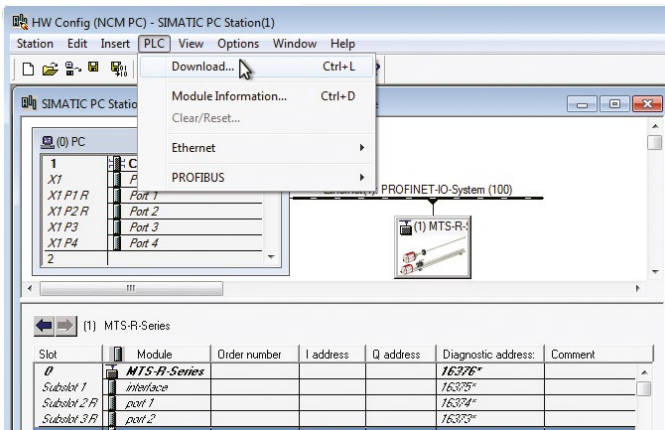

Fig. 71: Transfer settings to the control system (source: Siemens)

6.6 Integration and configuration of the sensors with encoder profile

- Step 1: Configuration of the network interface
- Step 2: Configuration of the sensor designation
- Step 3: Controller setting and preparation of the network
- Step 4: Integration of GSDML files (of the sensor)
- Step 5: Integration and configuration of the sensors
 - a) with U402 profile (MTS profile)
 - b) with U401 profile (encoder profile 4.1) ¹¹

- Select the encoder profile 4.1 from the directory displayed on the right (Fig. 72).

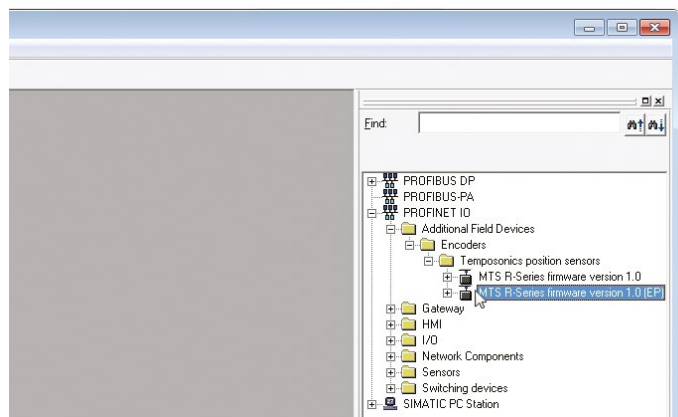

Fig. 72: Select Encoder profile 4.1 (source: Siemens)

- Select for U401 the file “MTS R-Series firmware version 1.0 (EP)”. Drag and drop this file from the directory and drop it into the network (dashed line). The sensor has been added to the network (Fig. 73).

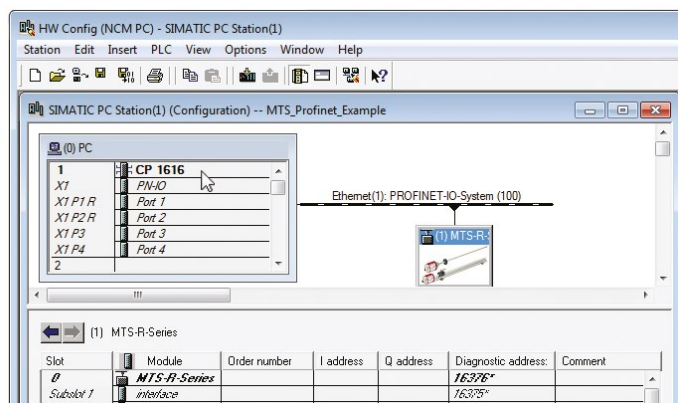

Fig. 73: Add sensor to the network (source: Siemens)

- Double-click on the MTS R-Series icon to select the sensor and enter the previously defined name into field “Device name”. Click “OK” to confirm your entries. Now you can double-click on “Slot 1”, “Subslot 1” (process data) to setup the sensors parameterization. Select tab “Parameters” to realize the following sensor settings:

^{11/} Depending on the integrated profile

a) Code sequence:

Specifies the measurement direction for position measurement
CW = forward (from sensor electronics housing to rod end)
CCW = reverse (from rod end to sensor electronics housing)

b) Class 4 functionality:

Activating / deactivating the following parameters: Code sequence, scaling function, measuring step, total measuring range, velocity unit and G1_XIST1 preset control. With “Class 4 functionality” de-activated, the sensor measures with a resolution of 1 µm.

Any configured “Preset” is not taken into account and the measuring direction is forward. If the parameter “G1_XIST1 preset control” is activated this will affect G1_XIST1, G1_XIST2 and G1_XIST3.

c) G1_XIST1 preset control:

Specifies the effect of a preset on G1_XIST1. If Class 4 functionality is activated and G1_XIST1 preset control is disabled, the position value in G1_XIST1 will not be affected by a preset. Should be selected, if the preset should have an impact not only on G1_XIST2 and G1_XIST3, but also on G1_XIST1.

d) Scaling function control:

Activating / deactivating the scaling function. The “Scaling function”- parameter can be used to change the encoder resolution. Note that the “Scaling function” parameters can be activated only, if “Class 4 functionality” and “Scaling function control” are activated. Otherwise, the scaling function is disabled and the resolution is 1 µm.

e) Alarm channel control:

Activating / deactivating the alarm channel. This parameter is used to limit the amount of data sent. This parameter is only supported in compatibility mode and can be deactivated only in compatibility mode.

f) Compatibility mode:

Activating / deactivating the compatibility mode. This parameter indicates, if the sensor should run in a mode compatible with encoder profile 3.1. The functions which are affected when this parameter is activated are listed in the table below.

Attribute	Meaning	Value
Enable	Compatibility with encoder profile V3.1	0
Disable	No backward compatibility (default)	1
Function	Compatibility mode enabled (= 0)	Compatibility mode disabled (= 1)
Control by PLC (STW2_ENC)	Ignored, the control word (G1_STW) and the set point values are always valid. Control requested (ZSW2_ENC) is not supported and is set to 0.	Supported
User parameter alarm channel control	Supported	Not supported, the application alarm channel is active and controlled by a PROFIdrive parameter.
P965 Profile Version	31 (V3.1)	41 (V4.1)

g) Measurement step (high DWORD):

Position measurement resolution 1, 2, 5, 10, 50, 100 µm, provided that the “Scaling function” is activated.

h) Measurement step (low DWORD):

Position measurement resolution 1, 2, 5, 10, 50, 100 µm, provided that the “Scaling function” is activated.

i) Measurement range (high DWORD):

Limits the measuring range to the number of measurement steps, provided that the “Scaling function” is activated.

j) Measurement range (low DWORD):

Limits the measuring range to the number of measurement steps, provided that the “Scaling function” is activated.

k) Maximum master sign-of-life failures:

Specifies the number of allowed failures of the masters sign-of-life. This parameter is only supported in compatibility mode.

l) Velocity unit ¹²:

Specifies the coding of the velocity units used to configure the signals NIST_A and NIST_B.

Parameter	Meaning	Value
Velocity measuring units	Definition of the units for the sensor velocity output value	See below
Velocity measuring units		Value
Steps/s		0
Steps/100 ms		1
Steps/10ms		2
RPM (= mm/s)		3

m) Preset value:

The preset value function enables adaptation of the position value from the sensor to a mechanical reference point. The preset function sets the actual position of the sensor to zero (= default value) or to the selected preset value. The preset function is controlled by bits in the control word (G1_STW) and acknowledged by a bit in the status word (G1_ZSW). A preset value can be set more than once. It can be stored to the nonvolatile memory using PROFIdrive parameter 971. The preset function has an absolute and a relative operating mode selectable by bit 11 in the control word (G1_STW). Bit 11 and bit 12 in the control word controls the preset in the following way:

Normal operating mode: Bit 12 = 0

In this mode the sensor will not change the output value.

Preset mode absolute: Bit 11 = 0 and Bit 12 = 1

In this mode the sensor calculates an internal offset value from the preset value and the current position value. The position value is then shifted with the calculated offset value to get a position value equal to the preset value.

Preset mode relative: Bit 11 = 1 and Bit 12 = 1

In this mode the position value is shifted by the preset value. This value can be a negative or a positive value and is set by sensor parameter 65000 or 65002.

¹²/ A “step” corresponds to the selected resolution

The following steps are recommended when modifying the preset value parameters:

1. Read the requested preset value parameter and check if the returned value meets the application requirements.
If not, proceed with the following steps:
2. Write the preset value into the individual parameter.
3. Store the value in the nonvolatile memory by PROFdrive parameter 971 if the value should be valid also after the next power on sequence.

It is recommended to use the preset function only at sensors standstill.

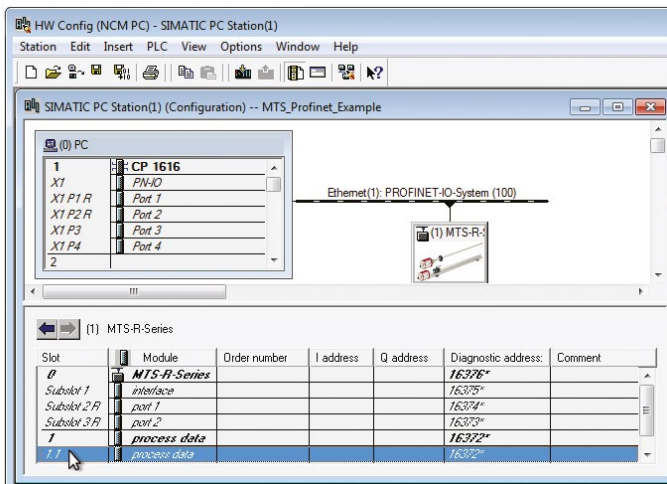

Fig. 74: Properties – process data (source: Siemens)

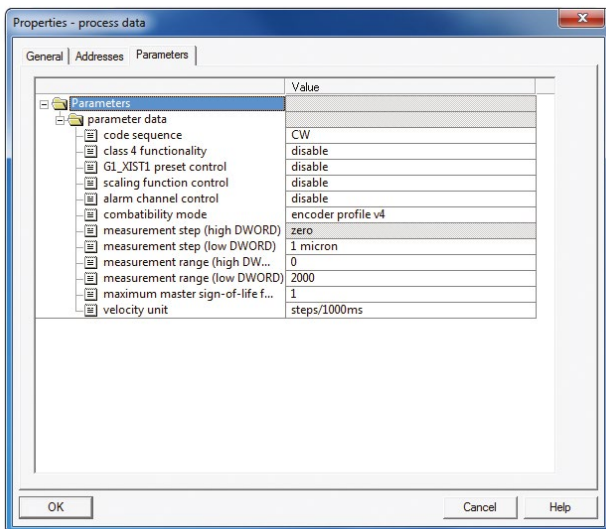

Fig. 75: Properties – process data (source: Siemens)

4. Select a standard telegram for output of the sensor position (Fig. 76). For this purpose, right-click "Slot 1", Subslot "2". Then, select:
 - Insert object
 - MTS R-Series firmware version X
 - Process data
 - Standard telegram

For a description of the standard telegrams, see the tables on page 40...42.

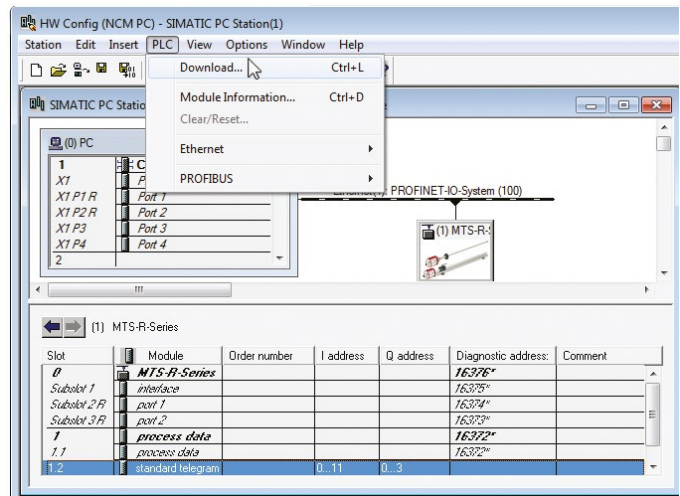

Fig. 76: Transfer settings to the control system (source: Siemens)

5. Transfer your settings to the control system as described below (Fig. 77):

- PLC
 - Download
 - CP1616
- Now you can access the input or output data of standard telegram 81 from your control program via addresses (example) 0...11 (I address) and 0...3 (Q address).

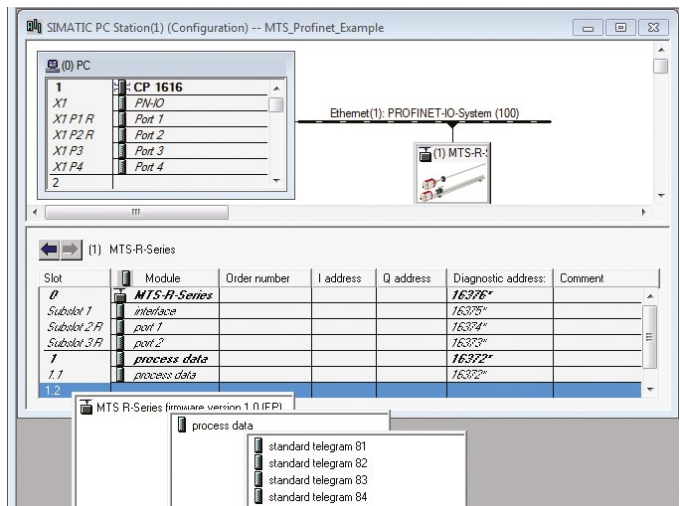

Fig. 77: Select standard telegram (source: Siemens)

Standard telegram 81

Standard telegram 81 uses 4 bytes for output data from the IO controller to the sensor and 12 bytes of input data from the sensor to the IO-controller.

Output data from the IO controller (control → sensor)

IO Data	1		2	
Byte	0	1	2	3
Actual value	STW2_ENC		G1_STW	
Description	Encoder control word 2		Sensor control word	

Input data to the IO controller (sensor → control)

IO Data	1		2		3		4		5		6	
Byte	0	1	2	3	4	5	6	7	8	9	10	11
Actual value	ZSW2_ENC		G1_ZSW		G1_XIST1				G1_XIST2			
Description	Status word 2		Status word		Position value				Position value 2			

Standard telegram 82

Standard telegram 82 uses 4 bytes for output data from the IO controller to the sensor and 14 bytes of input data from the sensor to the controller.

Output data from the IO controller (control → sensor)

IO Data	1		2	
Byte	0	1	2	3
Actual value	STW2_ENC		G1_STW	
Description	Encoder Control Word 2		Sensor Control Word	

Input data to the IO controller (sensor → control)

IO Data	1		2		3		4		5		6		7	
Byte	0	1	2	3	4	5	6	7	8	9	10	11	12	13
Actual value	ZSW2_ENC		G1_ZSW		G1_XIST1				G1_XIST2				NIST_A	
Description	Status word 2		Status word		Position value				Position value 2				Velocity	

Standard telegram 83

Standard telegram 83 uses 4 bytes for output data from the controller to the sensor and 16 bytes of input data from the sensor to the controller.

Output data from the IO controller (control → sensor)

IO Data	1		2	
Byte	0	1	2	3
Actual value	STW2_ENC		G1_STW	
Description	Encoder Control Word 2		Sensor Control Word	

Input data to the IO controller (sensor → control)

IO Data	1		2		3		4		5		6		7		8	
Byte	0	1	2	3	4	5	6	7	8	9	10	11	12	13	14	15
Actual value	ZSW2_ENC		G1_ZSW		G1_XIST1				G1_XIST2				NIST_B			
Description	Status word 2		Status word		Position value				Position value 2				Velocity			

Standard telegram 84

Standard telegram 84 uses 4 bytes for output data from the controller to the sensor and 20 bytes of input data from the sensor to the controller.

Output data from the IO controller (control → sensor)

IO Data	1		2	
Byte	0	1	2	3
Actual value	STW2_ENC		G1_STW	
Description	Encoder control word 2		Sensor control word	

Input data to the IO controller (sensor → control)

IO Data	1		2		3		4		5		6		7		8		9		10	
Byte	0	1	2	3	4	5	6	7	8	9	10	11	12	13	14	15	16	17	18	19
Actual value	ZSW2_ENC		G1_ZSW		G1_XIST3						G1_XIST2				NIST_B					
Description	Status word 2		Status word		Position value						Position value 2				Velocity					

Source: PROFIBUS Nutzerorganisation e.V.; 2008; Profile Encoder Technical Specification for PROFIBUS and PROFINET related to PROFIdrive Version 4.1

Control word 2 (STW2_ENC)			
Bit	Value	Significance	Comments
0...6	–	–	Reserved
7	$\frac{1}{0}$	Fault acknowledge (0 → 1)	The fault signal is acknowledged with a positive edge; the sensor reaction to a fault depends on the type of fault.
8, 9	–	–	Reserved
10	1	Control by PLC	Control via interface, EO IO data is valid.
	0	No control by PLC	EO IO data not valid; except sign-of-life.
11	–	–	Reserved
12...15	–	Controller sign-of-life	Not supported
Status word 2 (ZSW2_ENC)			
Bit	Value	Significance	Comments
0...2	–	–	Reserved
3	1	Fault present	Unacknowledged faults or currently not acknowledged faults (fault messages) are present (in the buffer). The fault reaction is fault-specific and device-specific. The acknowledging of a fault may only be successful, if the fault cause has disappeared or has been removed before. If the fault has been removed the sensor returns to operation. The related fault numbers are in the fault buffer.
	0	No fault	
4...8	–	–	Reserved
9	1	Control request	The automation system is requested to assume control.
	0	No control request	Control by automation system is not possible, only possible at the device or by another interface.
10, 11	–	–	Reserved
12...15	–	Encoder sign-of-life	Not supported
Sensor status word (G1_ZSW)			
Bit	Function		Comments
0...7	Reference mark search, measurement on the fly		–
8	Probe 1 deflected		–
9	Probe 2 deflected position mode (preset)		–
10	Reserved, set to zero		–
11	Requirements of error acknowledgment detected		–
12	Set / shift of home position (preset) executed		–
13	Transmit absolute value cyclically		If bit 13 transmits absolute value cyclically or bit 15 sensor error is not set there is no valid value or error code transferred in G1_XIST2. Bit 13 transmits absolute value cyclically cannot be set at the same time as bit 15 sensor error. These bits are used to indicate either a valid position value transmission (bit 13) or the error code transmission (bit 15) in G1_XIST2.
14	Parking sensor active		–
15	Sensor error		–
Sensor control word (G1_STW)			
Bit	Function		Comments
0...7	Reference mark search, measurement on the fly		
8...10	Reserved (without effect)		
11	Home position mode position mode (preset)		
12	Request set / shift of home position (preset)		
13	Request absolute value cyclically		
14	Activate parking sensor		If the sensor parking is activated (bit 14 = 1) the sensor is still on the bus with the slave sign-of-life active and the sensor error and diagnostics switched off.
15	Acknowledging a sensor error		

Source: PROFIBUS Nutzerorganisation e.V.; 2008; Profile Encoder Technical Specification for PROFIBUS and PROFINET related to PROFIdrive Version 4.1

Format of G1_XIST3

G1_XIST3 is a 64 bit position value which is used to support sensors with a resolution exceeding 32 bits.

Format definition for G1_XIST3:

- Binary format
- The actual position value is always right aligned, a shifting factor is not used.
- The settings in the encoder parameter data affect the position value in G1_XIST3 if class 4 is enabled.

IO data	1	2	3	4
Format	64 bit position value			

6.7 Error diagnosis

From HW Config, connect with the Profinet network for error diagnosis (Fig. 78). Subsequently, the actual device and controller status is displayed (Fig. 79).

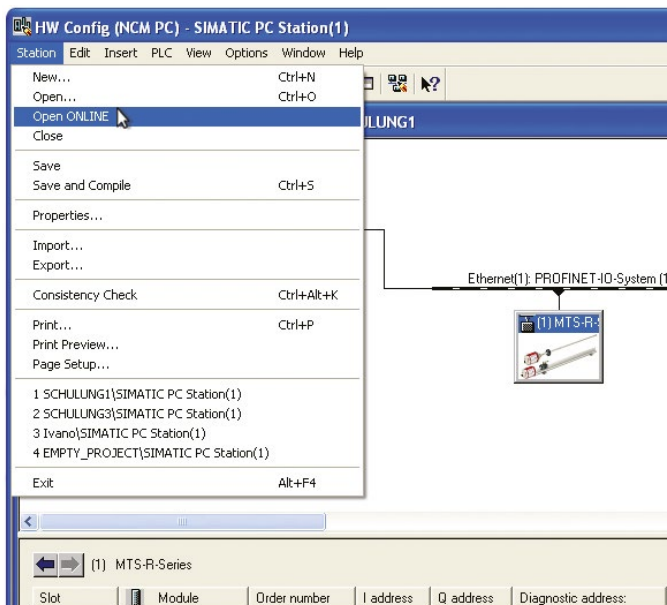

Fig. 78: Connect to Profinet sensor (source: Siemens)

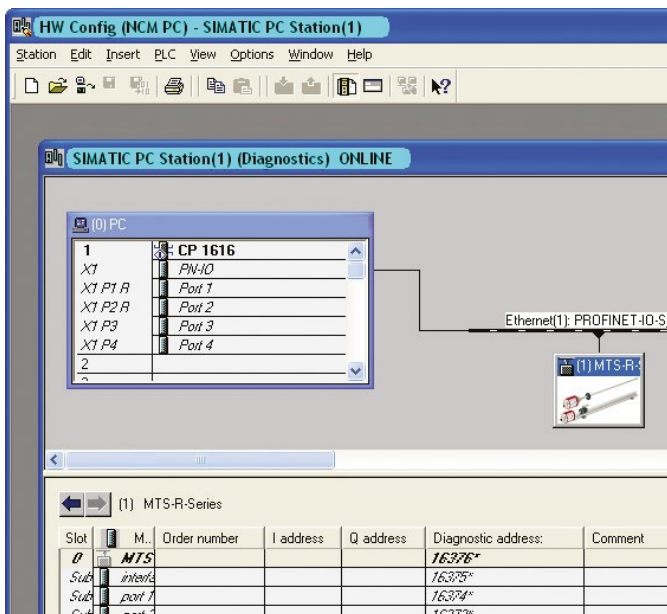

Fig. 79: Device and controller status (source: Siemens)

Devices with an error are marked with symbol  (Fig. 80).

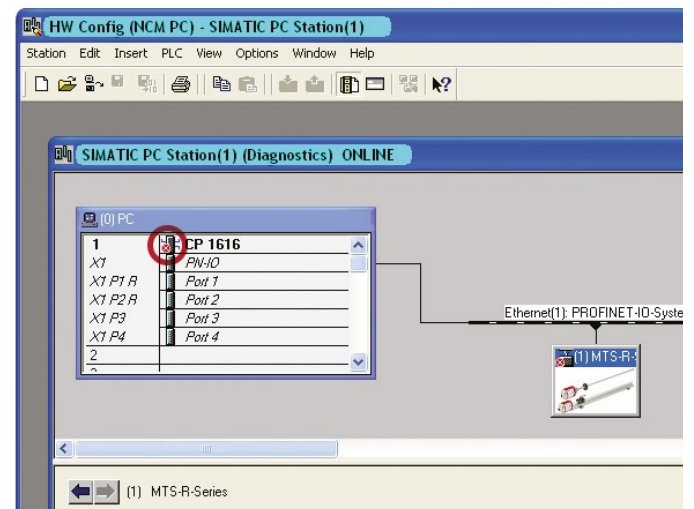



Fig. 80: Device marking in case of an error (source: Siemens)

For error diagnosis, double-click the device marked with symbol . Select tab "IO device diagnostics" to view the error details. In the example, a position magnet is missing for a Temposonics® sensor with MTS profile (Fig. 81).

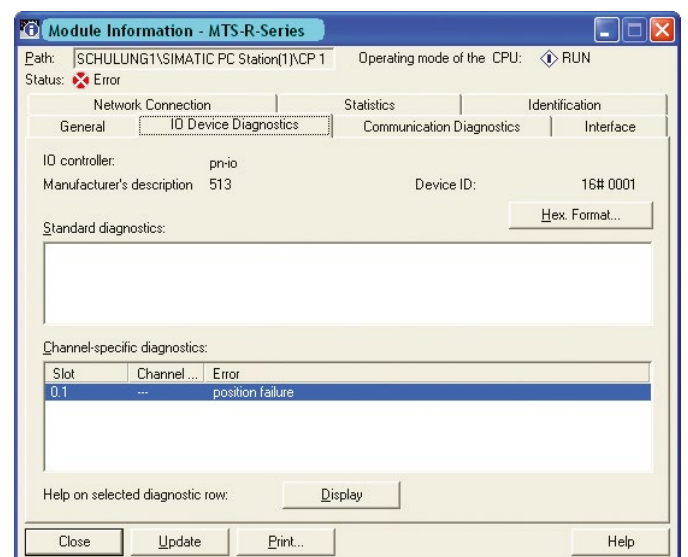

Fig. 81: Error diagnosis (example) (source: Siemens)

These diagnosis outputs are realized via alarm messages and Profinet interface. Temposonics® Profinet sensors support the following diagnosis alarms:

U402 (MTS Profile)	
Alarm ID	Meaning
17	Inadmissible operating voltage
27	Bad number of magnets
U401 (Encoder Profile)	
Alarm ID	Meaning
36865	High operating voltage
36866	Low operating voltage
36874	Bad number of magnets

7. Maintenance and troubleshooting

7.1 Error conditions, troubleshooting

See chapter "5. Operation" on page 31.

7.2 Maintenance

The sensor is maintenance-free.

7.3 Repair

Repairs of the sensor may be performed only by MTS Sensors or a repair facility explicitly authorized by MTS Sensors.

7.4 List of spare parts

No spare parts are available for this sensor.

7.5 Transport and storage

The conditions of transport and storage of the sensor match the operating conditions mentioned in this document.

8. Removal from service / dismantling

The product contains electronic components and must be disposed of in accordance with the local regulations.

9. Technical data

9.1 Technical data Temposonics® RP

Output

Interface	Profinet IO
Data protocol	RT
Data transmission rate	100 MBit/s maximum
Measured value	Position or velocity / option: Multi-position measurement 2...19 positions or velocities

Measurement parameters

Resolution: Position	1, 2, 5, 10, 50, 100 µm selectable			
Resolution: Velocity	1 mm/s			
Cycle time	1000 mm (39.4 in.)	2000 mm (78.7 in.)	4000 mm (157.5 in.)	7000 mm (275.6 in.)
	1000 µs	2000 µs	4000 µs	7000 µs
Linearity ¹³	< ±0.01 % F.S. (minimum ±50 µm)			
Repeatability	< ±0.001 % F.S. (minimum ±2.5 µm)			
Hysteresis	< 4 µm typical			
Temperature coefficient	< 15 ppm/K typical			

Operating conditions

Operating temperature	-40...+75 °C (-40...+167 °F)
Humidity	90 % relative humidity, no condensation
Ingress protection ¹⁴	IP65 (correctly fitted)
Shock test	100 g (single shock), IEC standard 60068-2-27
Vibration test	15 g (10...2000 Hz), IEC standard 60068-2-6 (resonance frequencies excluded)
EMC test	Electromagnetic immunity EN 61000-6-2 Electromagnetic emission EN 61000-6-3 The sensor meets the requirements of the EU directives and is marked with CE
Magnet movement velocity	Any (with magnet slider: Maximum 10 m/s)

Design / Material

Sensor electronics housing	Aluminum
Sensor profile	Aluminum
Stroke length	25...5080 mm (1...200 in.)

Mechanical mounting

Mounting position	Any
Mounting instruction	Please consult the technical drawings

Electrical connection

Connection type	2 × M12 female connector (5 pin), 1 × M12 female connector (4 pin)
Operating voltage ¹⁵	+24 VDC (-15 / +20 %); UL recognition requires an approved power supply with energy limitation (UL 61010-1), or Class 2 rating according to the National Electrical Code (USA) / Canadian Electrical Code.
Ripple	≤ 0.28 V _{pp}
Current consumption ¹⁵	110 mA typical
Dielectric strength	500 VDC (DC ground to machine ground)
Polarity protection	Up to -30 VDC
Overvoltage protection	Up to 36 VDC

¹³/With position magnet # 252 182

¹⁴/The IP rating is not part of the UL approval

¹⁵/Power supply must be able to provide current of 1A for power up process

9.2 Technical data Temposonics® RH

Output

Interface/Data protocol	Profinet IO
Data protocol	RT
Data transmission rate	100 MBit/s maximum
Measured value	Position or velocity / option: Multi-position measurement 2...19 positions or velocities

Measurement parameters

Resolution: Position	1, 2, 5, 10, 50, 100 µm selectable			
Resolution: Velocity	1 mm/s			
Cycle time	1000 mm (39.4 in.)	2000 mm (78.7 in.)	4000 mm (157.5 in.)	7000 mm (275.6 in.)
	1000 µs	2000 µs	4000 µs	7000 µs
Linearity ¹⁶	< ±0.01 % F.S. (minimum ±50 µm)			
Repeatability	< ±0.001 % F.S. (minimum ±2.5 µm)			
Hysteresis	< 4 µm typical			
Temperature coefficient	< 15 ppm/K typical			

Operating conditions

Operating temperature	-40...+75 °C (-40...+167 °F)
Humidity	90 % relative humidity, no condensation
Ingress protection ¹⁷	IP67 (correctly fitted)
Shock test	100 g (single shock), IEC standard 60068-2-27
Vibration test	15 g (10...2000 Hz), IEC standard 60068-2-6 (resonance frequencies excluded)
EMC test	Electromagnetic immunity EN 61000-6-2
	Electromagnetic emission EN 61000-6-3
	The sensor meets the requirements of the EU directives and is marked with CE
Operating pressure	350 bar (5076 psi); Peak: 700 bar (10,153 psi); RH-J: Peak 800 bar (11,603 psi)
Magnet movement velocity	Any

Design / Material

Sensor electronics housing	Aluminum
Flange	Stainless steel 1.4305 (AISI 303)
Sensor rod	Stainless steel 1.4306 (AISI 304L)
Stroke length	25...7620 mm (1...300 in.)

Mechanical mounting

Mounting position	Any
Mounting instruction	Please consult the technical drawings

Electrical connection

Connection type	2 × M12 female connector (5 pin), 1 × M12 female connector (4 pin)
Operating voltage ¹⁸	+24 VDC (-15 / +20 %); UL recognition requires an approved power supply with energy limitation (UL 61010-1), or Class 2 rating according to the National Electrical Code (USA) / Canadian Electrical Code.
Ripple	≤ 0.28 V _{pp}
Current consumption ¹⁸	110 mA typical
Dielectric strength	500 VDC (DC ground to machine ground)
Polarity protection	Up to -30 VDC
Overvoltage protection	Up to 36 VDC

¹⁶/With position magnet # 251416-2

¹⁷/The IP rating is not part of the UL approval

¹⁸/Power supply must be able to provide current of 1 A for power up process

9.3 Technical data Temposonics® RD4

Output

Interface	Profinet IO
Data protocol	RT
Data transmission rate	100 MBit/s maximum
Measured value	Position or velocity / option: Multi-position measurement 2...19 positions or velocities

Measurement parameters

Resolution: Position	1, 2, 5, 10, 50, 100 µm selectable			
Resolution: Velocity	1 mm/s			
Cycle time	1000 mm (39.4 in.)	2000 mm (78.7 in.)	4000 mm (157.5 in.)	7000 mm (275.6 in.)
	1000 µs	2000 µs	4000 µs	7000 µs
Linearity ¹⁹	< ±0.02 % F.S. (minimum ±50 µm) ²⁰			
Repeatability	< ±0.001 % F.S. (minimum ±2.5 µm) typical			
Hysteresis	< 4 µm typical			

Operating conditions

Operating temperature	-40...+75 °C (-40...+167 °F)
Humidity	90 % relative humidity, no condensation
Ingress protection for sensor electronics	IP67 (correctly fitted)
Ingress protection for sensor rod with connecting cable for side cable entry	IP65 (correctly fitted)
Ingress protection for sensor rod with single wires and flat connector with bottom cable entry	IP30 (correctly fitted)
Shock test	100 g (single shock), IEC standard 60068-2-27
Vibration test	10 g (10...2000 Hz), IEC standard 60068-2-6 (resonance frequencies excluded)
EMC test ²¹	Electromagnetic immunity EN 61000-6-2 Electromagnetic emission EN 61000-6-3
Operating pressure	350 bar (5076 psi); peak: 700 bar (10,153 psi)
Magnet movement velocity	Any

Design / Material

Sensor electronics housing	Aluminum
Flange	Stainless steel 1.4305 (AISI 303)
Sensor rod	Stainless steel 1.4306 (AISI 304L)
Stroke length	25...5080 mm (1...200 in.)

Mechanical mounting

Mounting position	Any
Mounting instruction	Please consult the technical drawings

Electrical connection

Connection type	2 × M12 female connector (5 pin), 1 × M12 female connector (4 pin)
Operating voltage ²²	+24 VDC (-15 / +20 %)
Ripple	≤ 0.28 V _{pp}
Current consumption ²²	110 mA typical
Dielectric strength	500 VDC (DC ground to machine ground)
Polarity protection	Up to -30 VDC
Overvoltage protection	Up to 36 VDC

¹⁹/With position magnet # 251416-2

²⁰/For pressure fit flange »S« the linearity deviation can be higher in the first 30 mm (1.2 in.) of stroke length

²¹/Sensor rod and connecting cable have to be mounted in a metal housing (e.g. in a cylinder)

²²/Power supply must be able to provide current of 1 A for power up process

9.4 Technical data Temposonics® RF

Output

Interface/Data protocol	Profinet IO
Data protocol	RT
Data transmission rate	100 MBit/s maximum
Measured value	Position or velocity / option: Multi-position measurement 2...19 positions or velocities

Measurement parameters

Resolution: Position	1, 2, 5, 10, 50, 100 µm selectable			
Resolution: Velocity	1 mm/s			
Cycle time	1000 mm (39.4 in.)	2000 mm (78.7 in.)	4000 mm (157.5 in.)	7000 mm (275.6 in.)
	1000 µs	2000 µs	4000 µs	7000 µs
Linearity ²³	< ±0.02 % F.S. (minimum ±100 µm)			
Repeatability	< ±0.001 % F.S. (minimum ±2.5 µm) typical			
Hysteresis	< 4 µm typical			

Operating conditions

Operating temperature	-40...+75 °C (-40...+167 °F)
Humidity ²⁴	90 % relative humidity, no condensation
Ingress protection	IP30 (correctly fitted) IP65 (rating only for professional mounted guide pipe and if mating connectors are correctly fitted)
Shock test	100 g (single shock), IEC standard 60068-2-27
Vibration test	5 g (10...150 Hz), IEC standard 60068-2-6 (resonance frequencies excluded)
EMC test	Electromagnetic immunity EN 61000-6-2 Electromagnetic emission EN 61000-6-3 The sensor meets the requirements of the EU directives and is marked with CE ²⁵
Magnet movement velocity	Any

Design / Material

Sensor electronics housing	Aluminum
Flange	Stainless steel 1.4305 (AISI 303)
Sensor rod	Stainless steel conduct with PTFE coating
Stroke length	150...20000 mm (4...787 in.)

Mechanical mounting

Mounting position	Any
Mounting instruction	Please consult the technical drawings

Electrical connection

Connection type	2 × M12 female connector (5 pin), 1 × M12 female connector (4 pin)
Operating voltage ²⁶	+24 VDC (-15 / +20 %)
Ripple	≤ 0.28 V _{pp}
Current consumption ²⁶	110 mA typical
Dielectric strength	500 VDC (DC ground to machine ground)
Polarity protection	Up to -30 VDC
Overvoltage protection	Up to 36 VDC

²³/With position magnet # 251 416-2

²⁴/For professional mounted guide pipe and if mating connectors are correctly fitted

²⁵/The conformity is fulfilled assumed the wave guide of the sensor is embedded in an EMC-sealed and grounded housing

²⁶/Power supply must be able to provide current of 1 A for power up process

10. Appendix

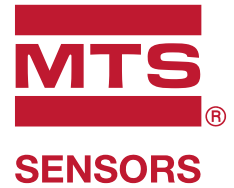

Safety Declaration

Dear Customer,

If you return one or several sensors for checking or repair, we need you to sign a safety declaration. The purpose of this declaration is to ensure that the returned items do not contain residues of harmful substances and / people handling these items will not be in danger.

MTS Sensors order number: _____ Sensor type(s): _____

Serial number(s): _____ Sensor length(s): _____

The sensor has been in contact with the following materials:

Do not specify chemical formulas.
Please include safety data sheets of the substances, if applicable.

In the event of suspected penetration of substances into the sensor, consult MTS Sensors to determine measures to be taken before shipment.

Short description of malfunction:

Corporate information

Company: _____

Address: _____

Contact partner

Name: _____

Phone: _____

E-Mail: _____

We hereby certify that the measuring equipment has been cleaned and neutralized.
Equipment handling is safe. Personnel exposure to health risks during transport and repair is excluded.

Stamp

Signature

Date

USA
MTS Systems Corporation Tel. +1 919 677-0100
Sensors Division Fax +1 919 677-0200
 3001 Sheldon Drive info.us@mtssensors.com
 Cary, N.C. 27513, USA www.mtssensors.com

GERMANY
MTS Sensor Technologie Tel. +49-23 51-95 87 0
GmbH & Co.KG Fax. +49-23 51-5 64 91
 Auf dem Schüffel 9 info.de@mtssensors.com
 58513 Lüdenscheid, Germany www.mtssensors.com

JAPAN
MTS Sensors Technology Corp. Tel. +81 42 775-3838
 737 Aihara-machi, Fax +81 42 775-5512
 Machida-shi, info.jp@mtssensors.com
 Tokyo 194-0211, Japan www.mtssensors.com

UNITED STATES 3001 Sheldon Drive
MTS Systems Corporation Cary, N.C. 27513
Sensors Division Phone: +1 919 677-0100
E-mail: info.us@mtssensors.com

GERMANY Auf dem Schüffel 9
MTS Sensor Technologie 58513 Lüdenscheid
GmbH & Co. KG Phone: +49 2351 9587-0
E-mail: info.de@mtssensors.com

ITALY Phone: +39 030 988 3819
Branch Office E-mail: info.it@mtssensors.com

FRANCE Phone: +33 1 58 4390-28
Branch Office E-mail: info.fr@mtssensors.com

GREAT BRITAIN Phone: +44 79 44 15 03 00
Branch Office E-mail: info.uk@mtssensors.com

CHINA Phone: +86 21 6485 5800
Branch Office E-mail: info.cn@mtssensors.com

JAPAN Phone: +81 3 6416 1063
Branch Office E-mail: info.jp@mtssensors.com

Document Part Number:
551416 Revision C (EN) 10/2018



www.mtssensors.com